

Chapter II

AC to DC CONVERSION (RECTIFIER)

- Single-phase, half wave rectifier
 - Uncontrolled
 - R load
 - R-L load
 - R-C load
 - Controlled
 - Free wheeling diode
- Single-phase, full wave rectifier
 - R load
 - R-L load,
 - Controlled R, R-L load
 - continuous and discontinuous current mode
- Three-phase rectifier
 - uncontrolled
 - controlled

Rectifiers

- **DEFINITION:** Converting AC (from mains or other AC source) to DC power by using power diodes or by controlling the firing angles of thyristors/controllable switches.
- Basic block diagram

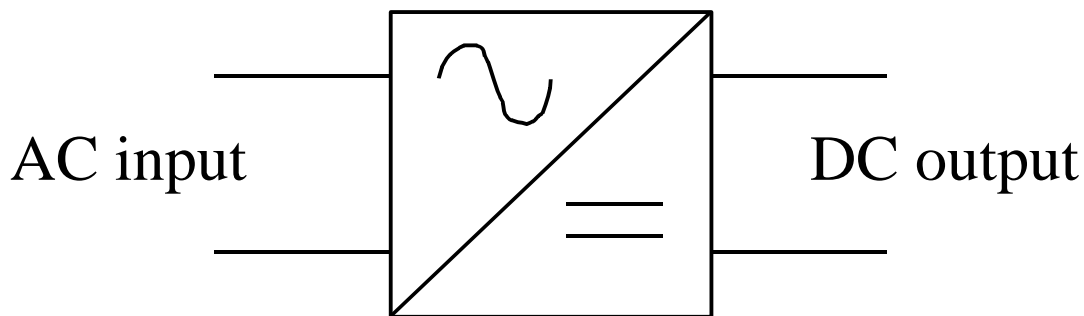

- Input can be single or multi-phase (e.g. 3-phase).
- Output can be made fixed or variable
- Applications: DC welder, DC motor drive, Battery charger, DC power supply

Single-phase, half-wave with R-load

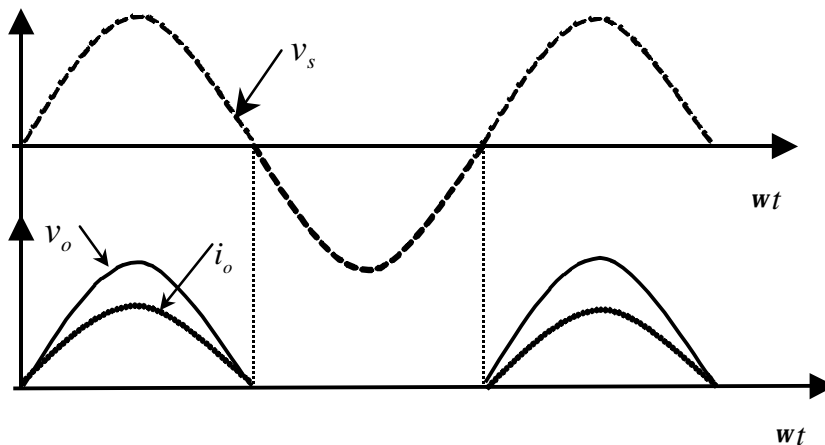
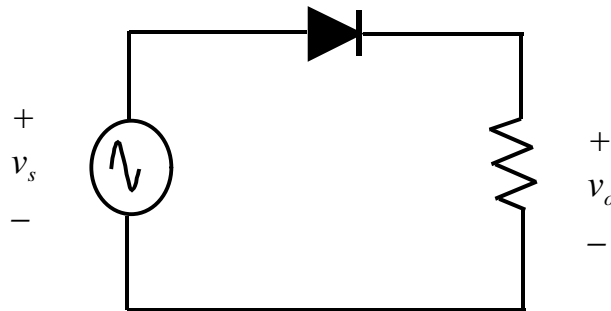

Output voltage (average),

$$V_o = V_{avg} = \int_0^p V_m \sin(\omega t) d\omega t$$
$$= \frac{V_m}{p} = 0.318V_m$$

RMS voltage

Output voltage (RMS)

$$V_{o,RMS} = \sqrt{\frac{1}{P} \int_0^P (V_m \sin(\omega t))^2 d\omega t} = \frac{V_m}{2}$$

Output current (DC),

$$I_o = \frac{V_o}{R} = \frac{0.318V_m}{pR}$$

- DC voltage is fixed at 0.318 or 31.8% of the peak value
- RMS voltage is reduced from 0.707 (normal sinusoidal RMS) to 0.5 or 50% of peak value.
- Half wave is not practical because of high distortion supply current. The supply current contains DC component that may saturate the input transformer

Half-wave with R-L load

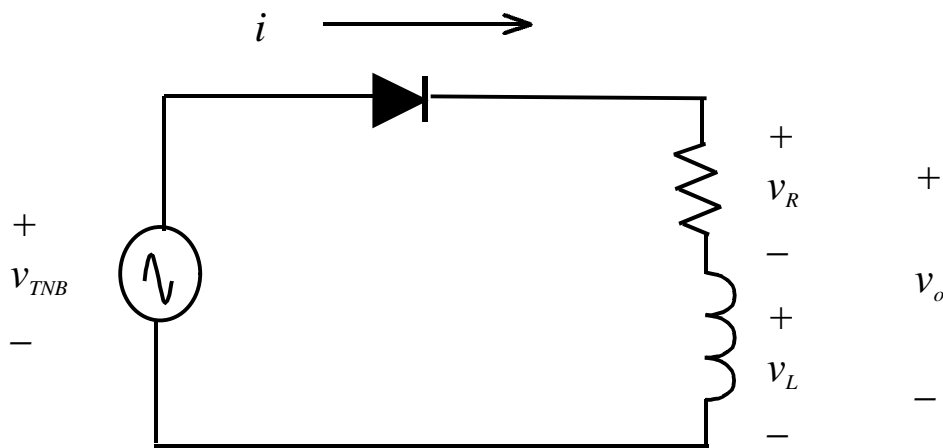

$$v_s = v_R + v_L$$

$$V_m \sin(\omega t) = i(t)R + L \frac{di(t)}{dt}$$

This is a first order differential equation.
Solution is in the form of :

$$i(t) = i_f(t) + i_n(t)$$

where : i_f, i_n are known as "forced" and "natural" response, respectively.

From diagram, forced response is :

$$i_f(t) = \left(\frac{V_m}{Z} \right) \cdot \sin(\omega t - \phi)$$

where :

$$Z = \sqrt{R^2 + (\omega L)^2} \quad \text{and} \quad \phi = \tan^{-1} \left(\frac{\omega L}{R} \right)$$

R-L load

Natural response is when source = 0,

$$i(t)R + L \frac{di(t)}{dt} = 0$$

which results in :

$$i_n(t) = Ae^{-t/\tau} \quad ; \tau = L/R$$

Hence

$$i(t) = i_f(t) + i_n(t) = \left(\frac{V_m}{Z} \right) \cdot \sin(\omega t - \phi) + Ae^{-t/\tau}$$

A can be solved by realising inductor current is zero before the diode starts conducting, i.e :

$$\begin{aligned} i(0) &= \left(\frac{V_m}{Z} \right) \cdot \sin(0 - \phi) + Ae^{-0/\tau} \\ \Rightarrow A &= \left(\frac{V_m}{Z} \right) \cdot \sin(-\phi) = \left(\frac{V_m}{Z} \right) \cdot \sin(\phi) \end{aligned}$$

Therefore the current is given as,

$$i(t) = \left(\frac{V_m}{Z} \right) \cdot \left[\sin(\omega t - \phi) + \sin(\phi) e^{-t/\tau} \right]$$

or

$$i(\omega t) = \left(\frac{V_m}{Z} \right) \cdot \left[\sin(\omega t - \phi) + \sin(\phi) e^{-\omega t/\omega\tau} \right]$$

R-L waveform

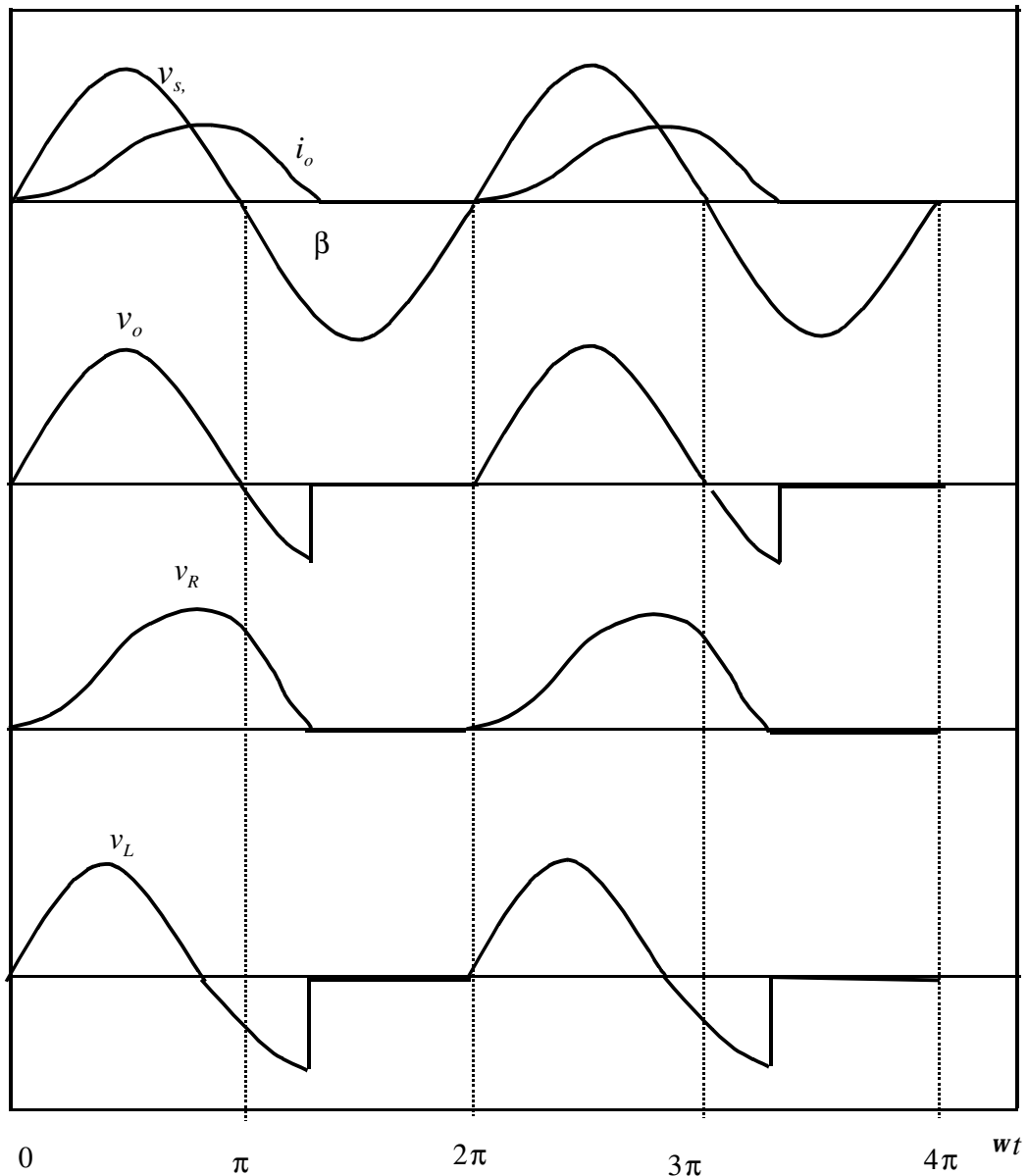

Note :

v_L is negative because the current is decreasing, i.e :

$$v_L = L \frac{di}{dt}$$

Extinction angle

Note that the diode remains in forward biased longer than π radians (although the source is negative during that duration)

The point when current reaches zero is when diode turns OFF. This point is known as the extinction angle, β .

$$i(\beta) = \left(\frac{V_m}{Z} \right) \cdot [\sin(\beta - \alpha) + \sin(\alpha) e^{-\beta/\omega t}] = 0$$

which reduces to :

$$\sin(\beta - \alpha) + \sin(\alpha) e^{-\beta/\omega t} = 0$$

β can only be solved numerically.

Therefore, the diode conducts between 0 and β

To summarise the rectifier with R - L load,

$$i(\omega t) = \begin{cases} \left(\frac{V_m}{Z} \right) \cdot [\sin(\omega t - \alpha) + \sin(\alpha) e^{-\omega t/\omega t}] & \text{for } 0 \leq \omega t \leq \beta \\ 0 & \\ \text{otherwise} & \end{cases}$$

RMS current, Power Factor

The average (DC) current is :

$$I_o = \frac{1}{2p} \int_0^{2p} i(\omega t) d\omega t = \frac{1}{2p} \int_0^b i(\omega t) d\omega t$$

The RMS current is :

$$I_{RMS} = \sqrt{\frac{1}{2p} \int_0^{2p} i^2(\omega t) d\omega t} = \sqrt{\frac{1}{2p} \int_0^b i^2(\omega t) d\omega t}$$

Power absorbed by the load is :

$$P_o = (I_{RMS})^2 \cdot R$$

Power Factor is computed from definition :

$$pf = \frac{P}{S}$$

where P is the real power supplied by the source, which equal to the power absorbed by the load.

S is the apparent power supplied by the source, i.e

$$S = (V_{s,RMS}) \cdot (I_{RMS})$$

$$\Rightarrow pf = \frac{P}{(V_{s,RMS}) \cdot (I_{RMS})}$$

Half wave rectifier, R-C Load

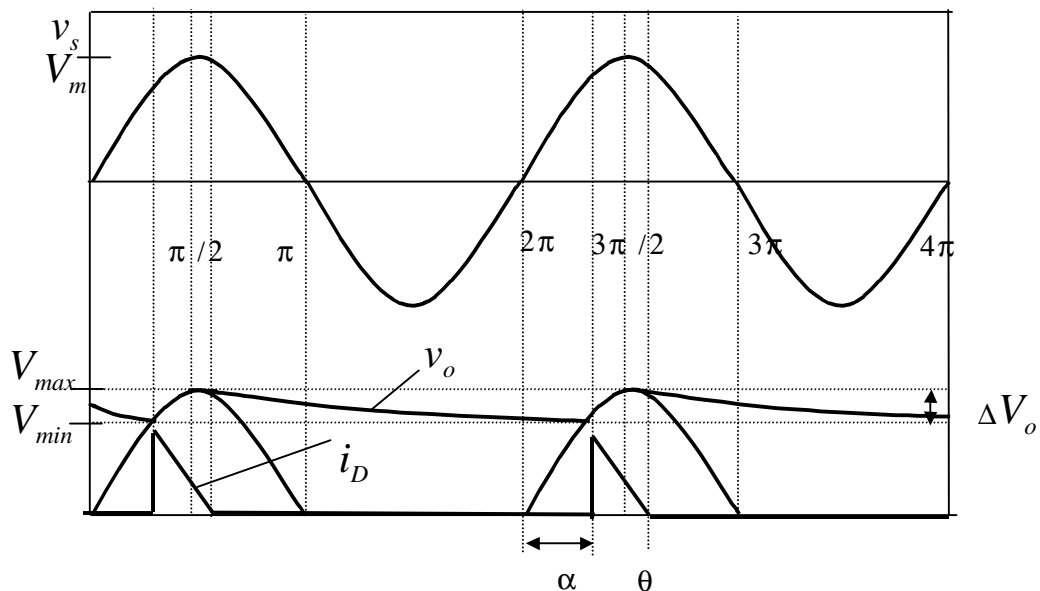
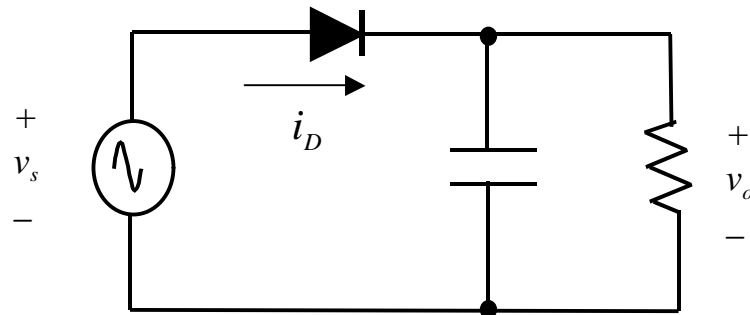

$$v_o = \begin{cases} V_m \sin(\omega t) & \text{when diode is ON} \\ V_q e^{-(\omega t - q) / \omega RC} & \text{when diode is OFF} \end{cases}$$

$$v_q = V_m \sin q$$

Operation

- Let C initially uncharged. Circuit is energised at $wt=0$
- Diode becomes forward biased as the source become positive
- When diode is ON the output is the same as source voltage. C charges until V_m
- After $wt=p/2$, C discharges into load (R).
- The source becomes less than the output voltage
- Diode reverse biased; isolating the load from source.
- The output voltage decays exponentially.

Estimation of θ

The slope of the functions are :

$$\frac{d(V_m \sin \omega t)}{d(\omega t)} = V_m \cos \omega t$$

and

$$\frac{d(V_m \sin q \cdot e^{-(\omega t - q)/\omega RC})}{d(\omega t)} = V_m \sin q \cdot \left(-\frac{1}{\omega RC} \right) \cdot e^{-(\omega t - q)/\omega RC}$$

At $\omega t = q$, the slopes are equal,

$$V_m \cos q = V_m \sin q \cdot \left(-\frac{1}{\omega RC} \right) \cdot e^{-(q - q)/\omega RC}$$

$$\Rightarrow \frac{V_m \cos q}{V_m \sin q} = -\frac{1}{\omega RC}$$

$$\frac{1}{\tan q} = \frac{1}{-\omega RC}$$

$$q = \tan^{-1}(-\omega RC) = -\tan^{-1}(\omega RC) + p$$

Estimation of α

For practical circuits, ωRC is large, then :

$$q = -\tan^{-1}(\infty) + p = -\frac{p}{2} + p = \frac{p}{2}$$

and $V_m \sin q = V_m$

At $\omega t = 2p + a$,

$$V_m \sin(2p + a) = (V_m \sin q) e^{-(2p + a - q)/\omega RC}$$

or

$$\sin(a - (\sin q) e^{-(2p + a - q)/\omega RC}) = 0$$

This equation must be solved numerically for a

Ripple Voltage

Max output voltage is V_{\max} .

Min output voltage occurs at $\omega t = 2p + a$

Referring to diagram, the ripple is :

$$\Delta V_o = V_{\max} - V_{\min}$$

$$= V_m - V_m \sin(2p + a) = V_m - V_m \sin a$$

If $V_q = V_m$ and $q = p/2$, and C is large such that DC output voltage is constant, then $a \approx p/2$.

The output voltage evaluated at $\omega t = 2p + a$ is :

$$v_o(2p + a) = V_m e^{-\left(\frac{2p + p/2 - p/2}{\omega RC}\right)} = V_m e^{-\left(\frac{2p}{\omega RC}\right)}$$

The ripple voltage is approximated as :

$$\Delta V_o \approx V_m - V_m e^{-\left(\frac{2p}{\omega RC}\right)} = V_m \left(1 - e^{-\left(\frac{2p}{\omega RC}\right)} \right)$$

Voltage ripple-cont'd

Approximation of exponent term yields :

$$e^{-2p/wRC} \approx 1 - \frac{2p}{wRC}$$

Substituting,

$$\Delta V_o \approx V_m \left(\frac{2p}{wRC} \right) = \frac{V_m}{fRC}$$

- The output voltage ripple is reduced by increasing C.
- As C is increased, the conduction interval for diode increases.
- Therefore, reduction in output voltage ripple results in larger peak diode current.
- **EXAMPLE:**
The half wave rectifier has 120V RMS source at 60Hz. R=500 Ohm and C=100uF. Determine (a) the expression for output voltage, (b) voltage ripple.

Controlled half-wave

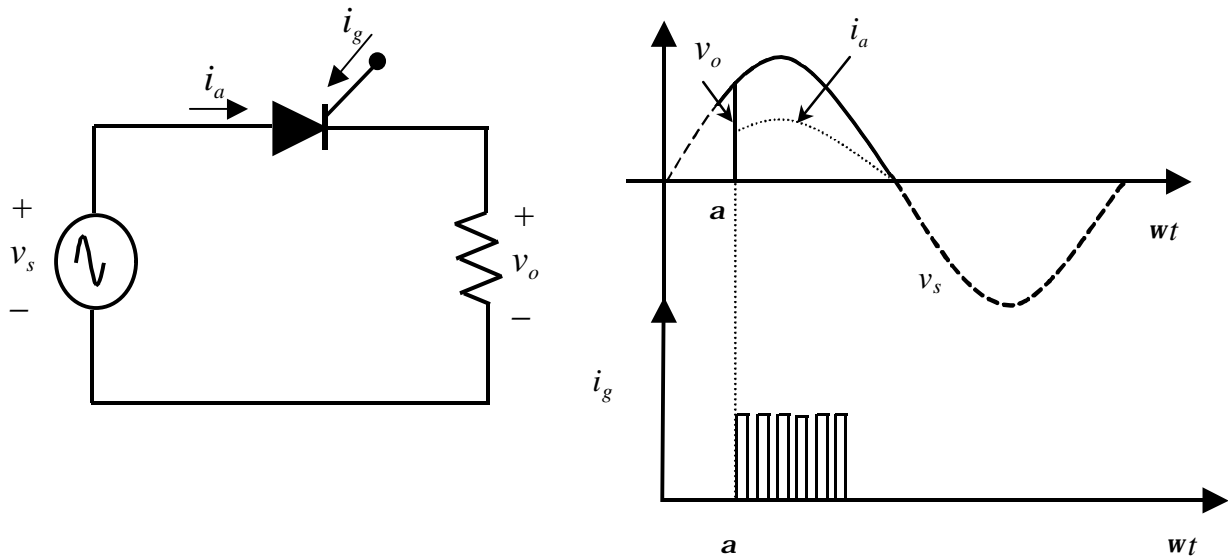

Average voltage :

$$V_o = \frac{1}{2p} \int_a^p V_m \sin(\omega t) d\omega t = \frac{V_m}{2p} [1 + \cos a]$$

RMS volatge

$$V_{RMS} = \sqrt{\frac{1}{2p} \int_a^p [V_m \sin(\omega t)]^2 d\omega t}$$

$$= \sqrt{\frac{V_m^2}{4p} \int_a^p [1 - \cos(2\omega t)] d\omega t} = \frac{V_m}{2} \sqrt{1 - \frac{a}{p} + \frac{\sin(2a)}{2p}}$$

Controlled h/w, R-L load

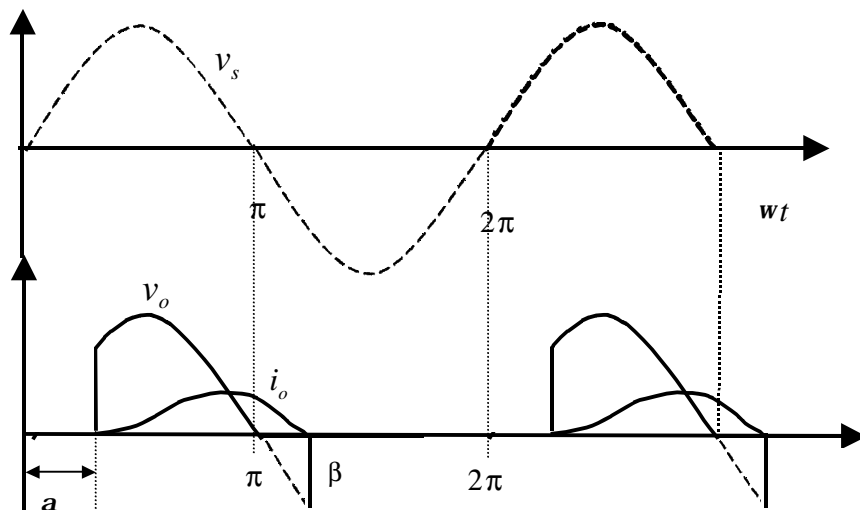
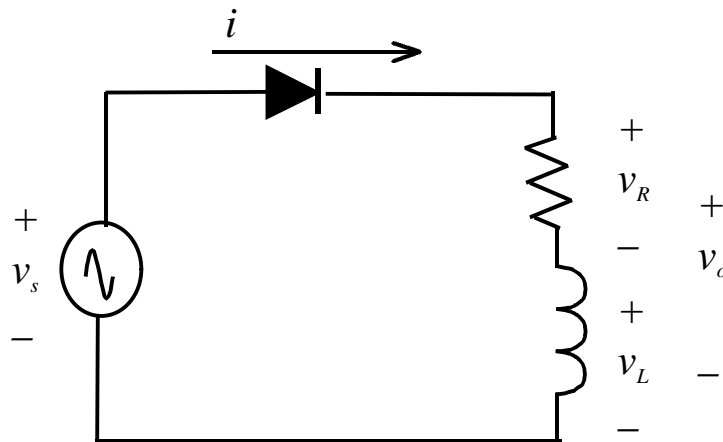

$$i(\omega t) = i_f(\omega t) + i_n(\omega t) = \left(\frac{V_m}{Z} \right) \cdot \sin(\omega t - q) + A e^{\frac{-\omega t}{\tau}}$$

Initial condition : $i(a) = 0$,

$$i(a) = 0 = \left(\frac{V_m}{Z} \right) \cdot \sin(a - q) + A e^{\frac{-a}{\tau}}$$

$$A = - \left[\left(\frac{V_m}{Z} \right) \cdot \sin(a - q) \right] e^{\frac{a}{\tau}}$$

Extinction angle

Substituting for A and simplifying,

$$i(\omega t) = \begin{cases} \left(\frac{V_m}{Z} \right) \cdot \left[\sin(\omega t - \phi) - \sin(\alpha - \phi) e^{-\frac{-(\alpha - \omega t)}{\omega T}} \right] & \text{for } \alpha \leq \omega t \leq \beta \\ 0 & \text{otherwise} \end{cases}$$

Extinction angle, β is defined when $i = 0$,

$$i(\beta) = 0 = \left(\frac{V_m}{Z} \right) \left[\sin(\beta - \phi) - \sin(\beta - \phi) e^{-\frac{(\alpha - \beta)}{\omega T}} \right]$$

which can only be solved numerically.

Angle $(\beta - \phi)$ is called the conduction angle.
i.e the diode conducts for θ degrees.

RMS voltage and current

Average voltage

$$V_o = \frac{1}{2p} \int_a^b V_m \sin(\omega t) d\omega t = \frac{V_m}{2p} [\cos a - \cos b]$$

Average current

RMS current

$$I_o = \frac{1}{2p} \int_a^b i(\omega t) d\omega t \quad I_{RMS} = \sqrt{\frac{1}{2p} \int_a^b i^2(\omega t) d\omega t}$$

The power absorbed by the load is:

$$P_o = I_{RMS}^2 \cdot R$$

- EXAMPLES
- 1. Design a circuit to produce an average voltage of 40V across a 100 ohm load from a 120V RMS, 60Hz supply. Determine the power factor absorbed by the resistance.
- 2. A half wave rectifier has a source of 120V RMS at 60Hz. R=20 ohm, L=0.04H, and the delay angle is 45 degrees. Determine: (a) the expression for $i(\omega t)$, (b) average current, (c) the power absorbed by the load.

Freewheeling diode (FWD)

- Note that for single-phase, half wave rectifier with R-L load, the load (output) current is NOT continuous.
- A FWD (sometimes known as commutation diode) can be placed as shown below to make it continuous

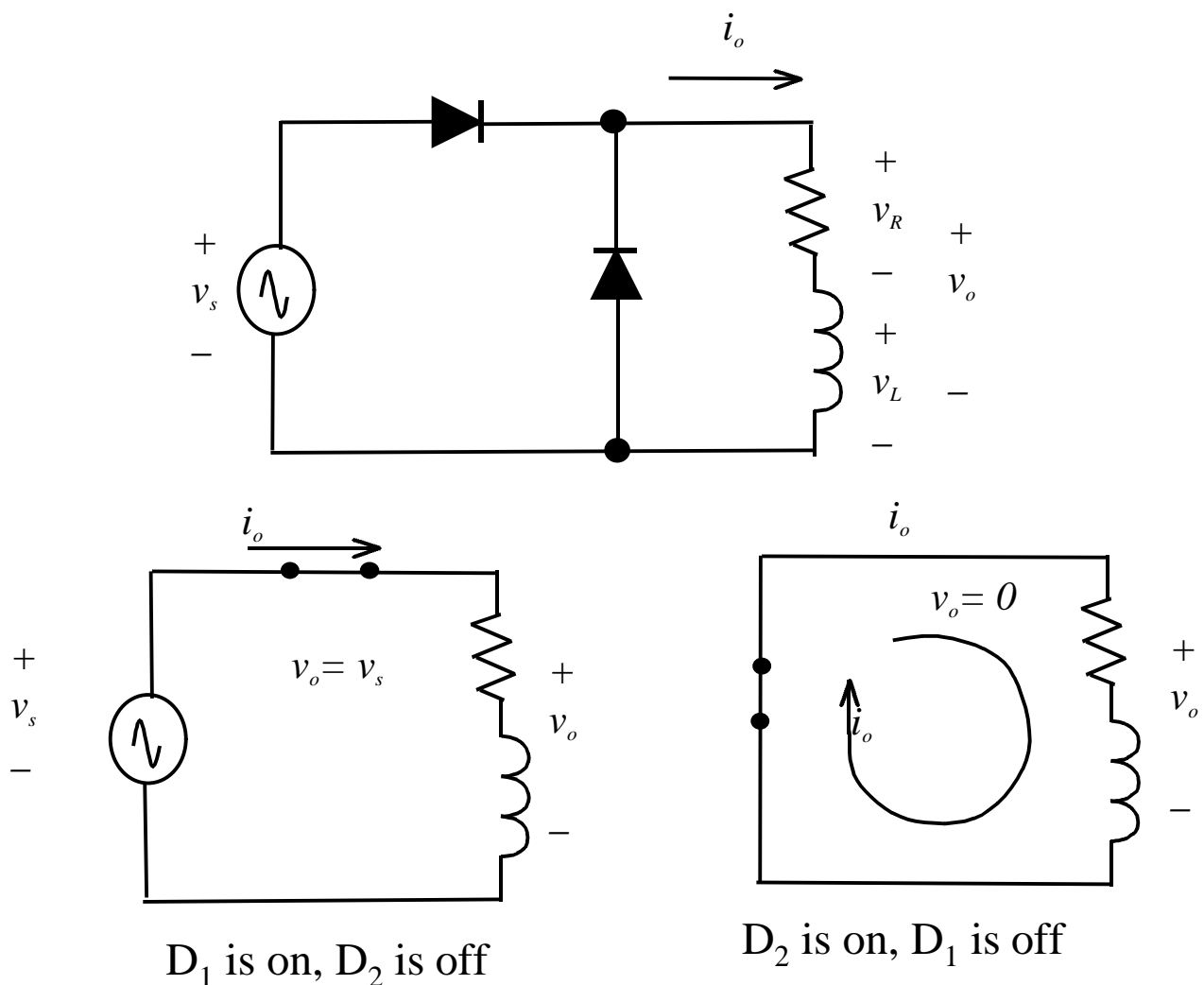

Operation of FWD

- Note that both D_1 and D_2 cannot be turned on at the same time.
- For a positive cycle voltage source,
 - D_1 is on, D_2 is off
 - The equivalent circuit is shown in Figure (b)
 - The voltage across the R-L load is the same as the source voltage.
- For a negative cycle voltage source,
 - D_1 is off, D_2 is on
 - The equivalent circuit is shown in Figure (c)
 - The voltage across the R-L load is zero.
 - However, the inductor contains energy from positive cycle. The load current still circulates through the R-L path.
 - But in contrast with the normal half wave rectifier, the circuit in Figure (c) does not consist of supply voltage in its loop.
 - Hence the “negative part” of v_o as shown in the normal half-wave disappear.

FWD- Continuous load current

- The inclusion of FWD results in continuous load current, as shown below.
- Note also the output voltage has no negative part.

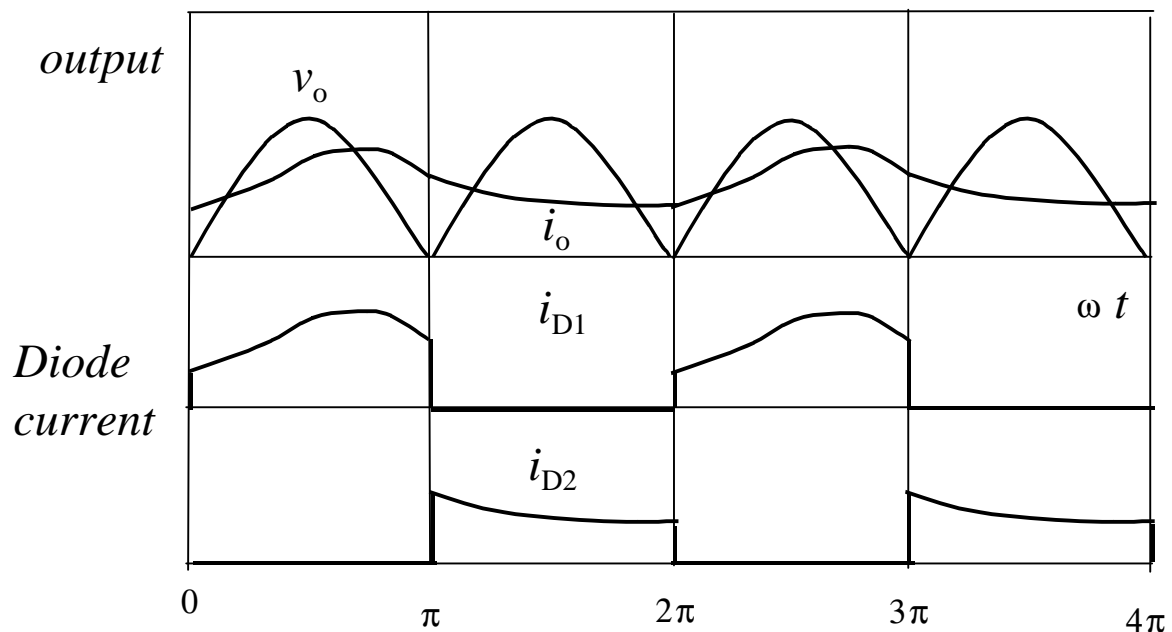

Full wave rectifier with R load

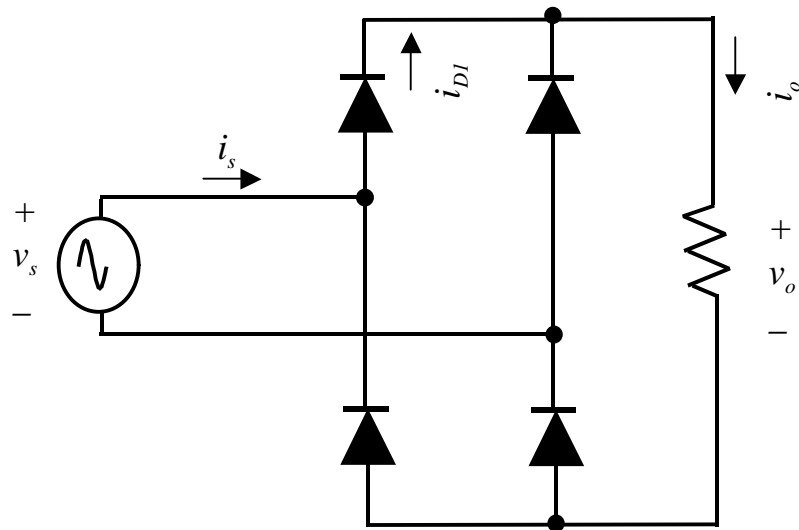

Bridge circuit

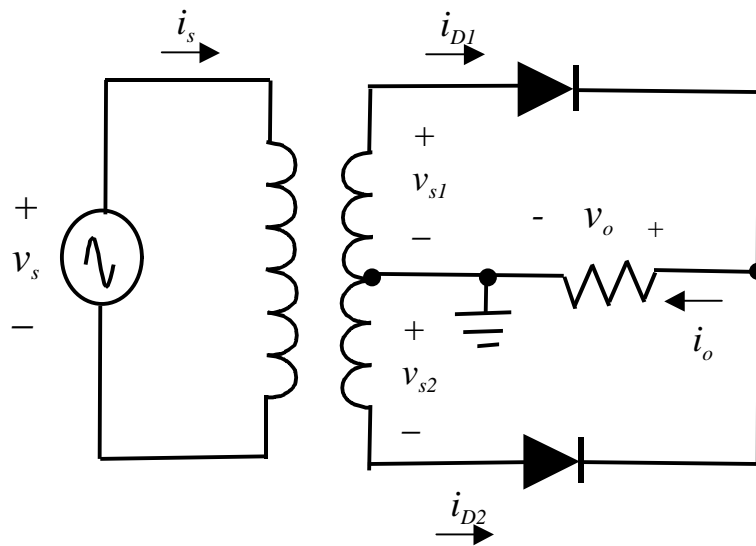

Center-tapped circuit

Notes on full-wave

- Center-tapped rectifier requires center-tap transformer. Bridge does not.
- Center tap requires only two diodes, compared to four for bridge. Hence, per half-cycle only one diode volt-drop is experienced. Conduction losses is half of bridge.
- However, the diodes ratings for center-tapped is twice than bridge.

For both circuits,

$$v_o = \begin{cases} V_m \sin wt & 0 \leq wt \leq p \\ V_m \sin wt & p \leq wt \leq 2p \end{cases}$$

DC voltage :

$$V_o = \frac{1}{p} \int_0^p V_m \sin(wt) dwt = \frac{2V_m}{p} = 0.637V_m$$

Bridge waveforms

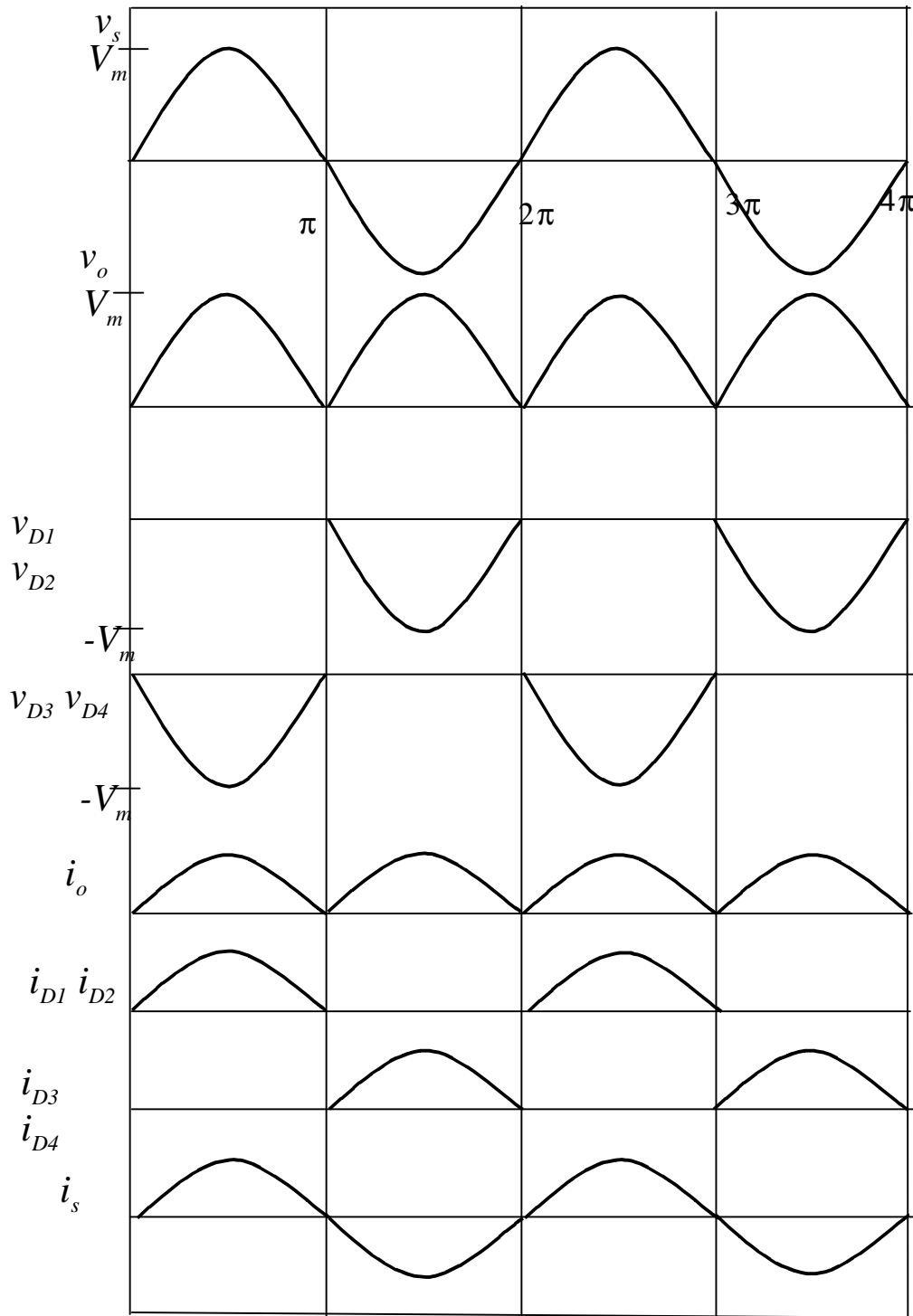

Center-tapped waveforms

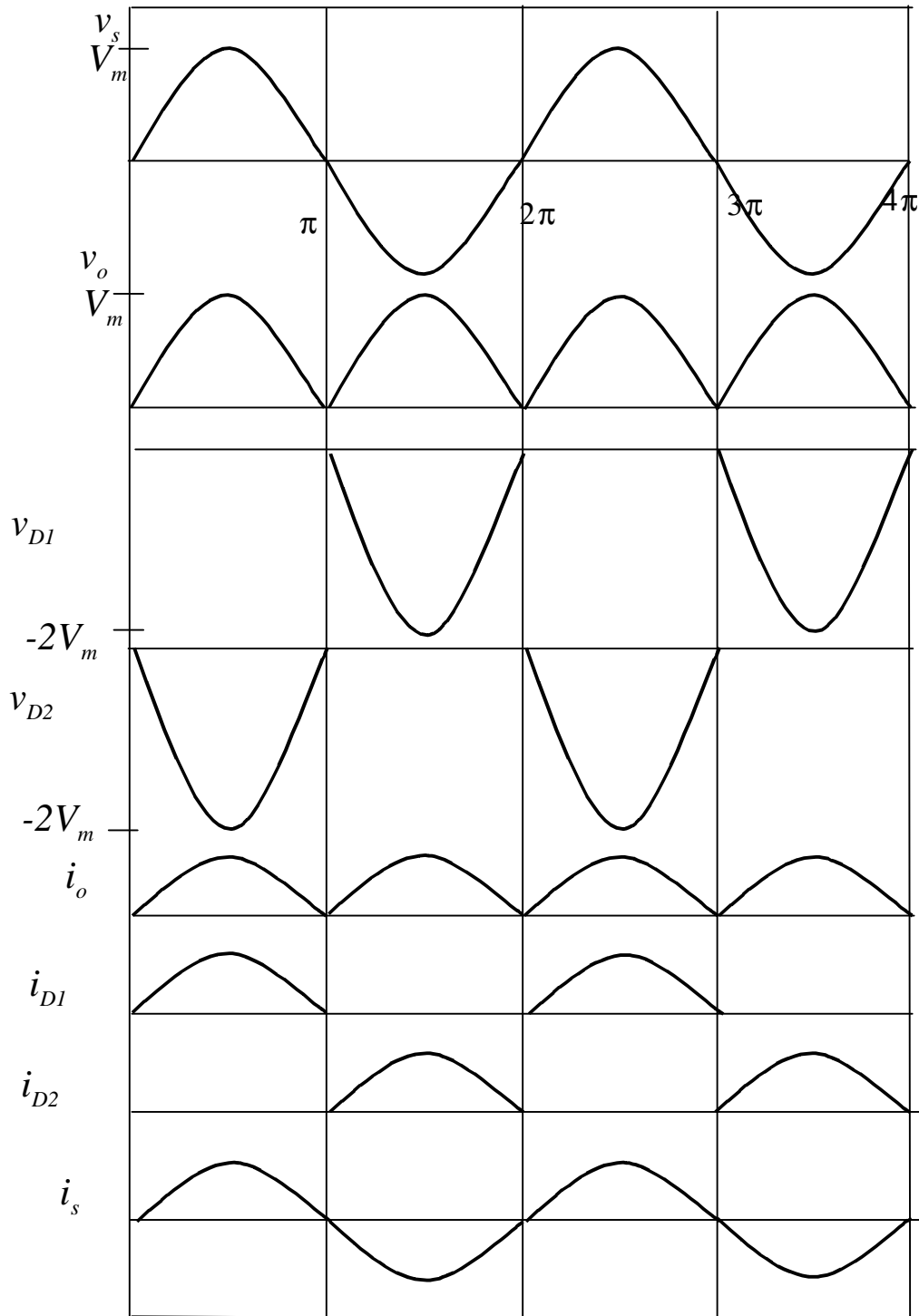

Full wave bridge, R-L load

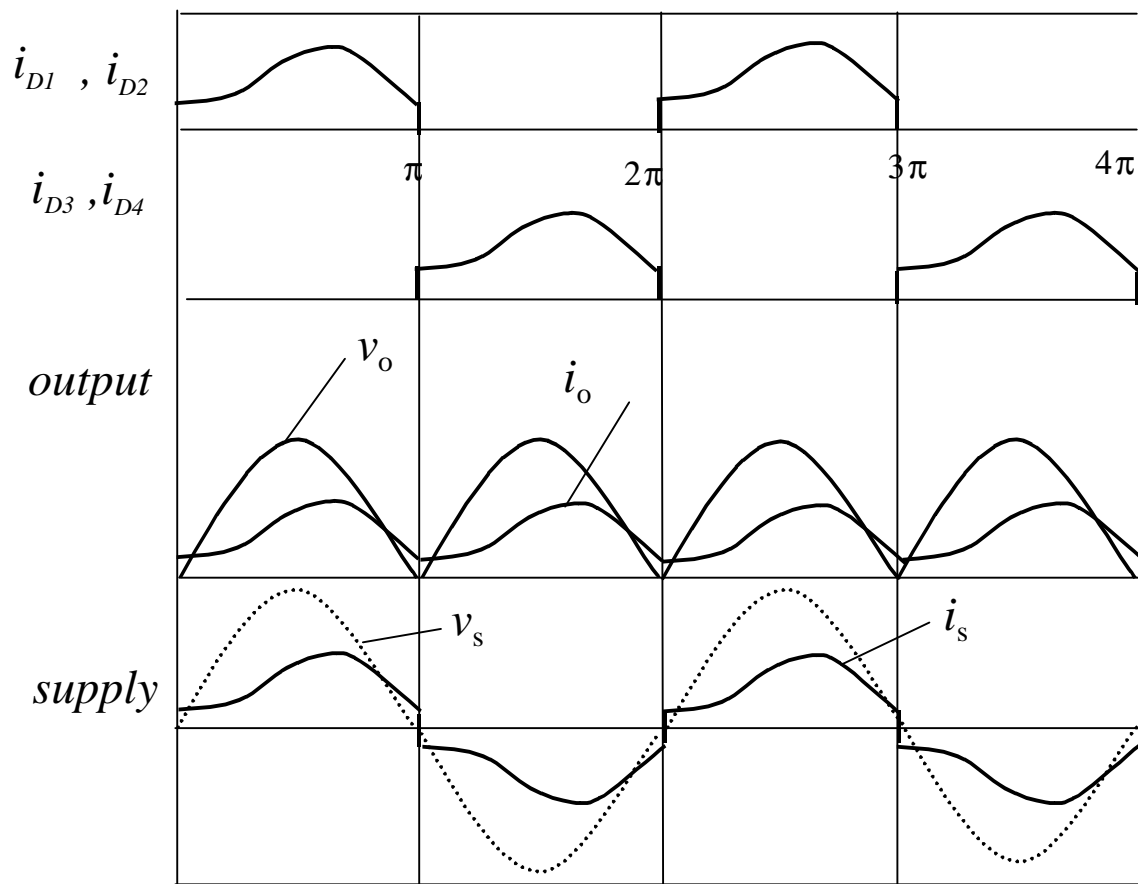
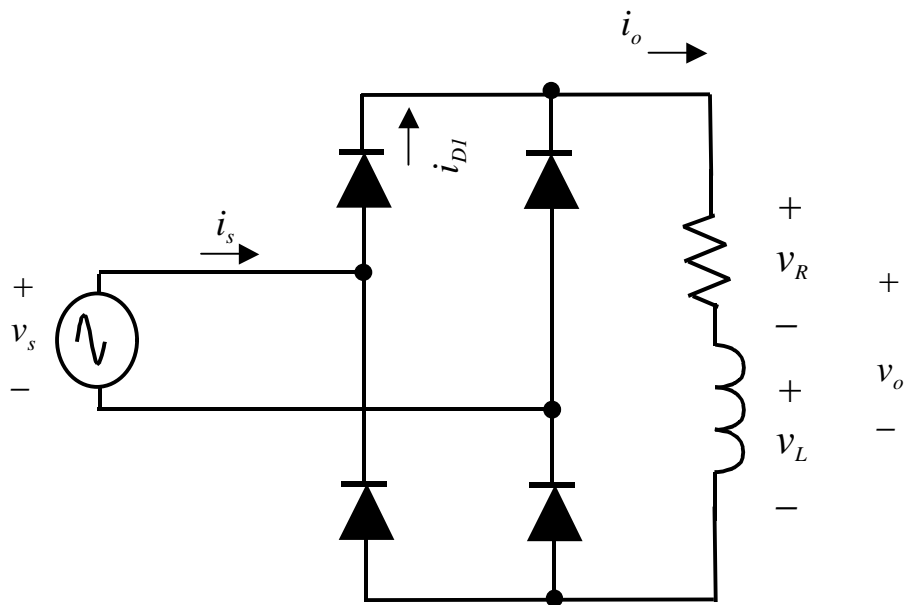

R-L load analysis: approximation with large L

Using Fourier Series, output voltage is described as :

$$v_o(\omega t) = V_o + \sum_{n=2,4,\dots}^{\infty} V_n \cos(n\omega t + \mathbf{p})$$

where

$$V_o = \frac{2V_m}{\pi}$$

$$V_n = \frac{2V_m}{\pi} \left(\frac{1}{n-1} - \frac{1}{n+1} \right)$$

The DC and harmonic currents are :

$$I_o = \frac{V_o}{R} \qquad I_n = \frac{V_n}{Z_n} = \frac{V_n}{|R + jn\omega L|}$$

Note that as n increases, voltage amplitude for the n th harmonic decreases.

This makes I_n decreases rapidly for increasing n . Only a few terms sufficient to approximate output.

R-L load analysis

If ωL is large enough, it is possible to drop all the harmonic terms, i.e.:

$$i(\omega t) \approx I_o = \frac{V_o}{R} = \frac{2V_m}{R}, \quad \text{for } \omega L \gg R,$$

The approximation with large L is shown below.

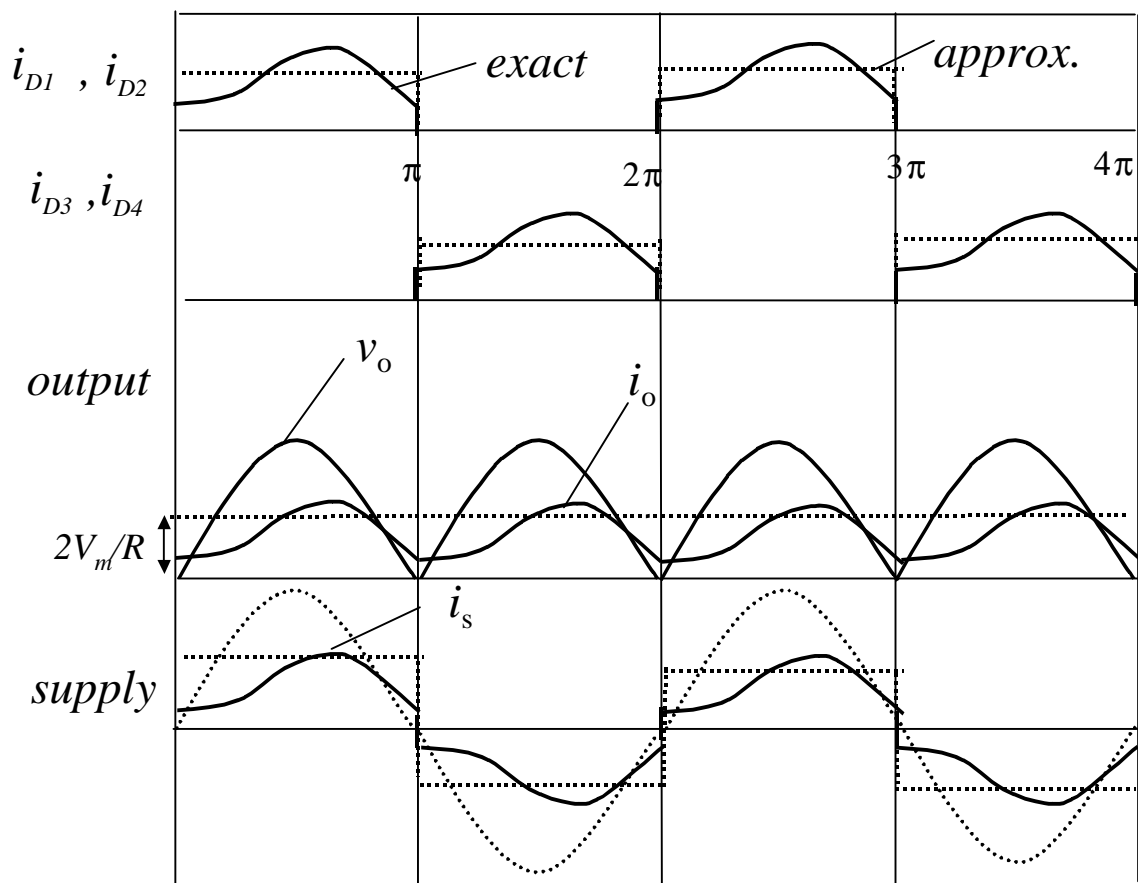

Examples

$$I_{RMS} = \sqrt{I_o^2 + \sum (I_{n,RMS}^2)} = I_o$$

Power delivered to the load : $P_o = I_{RMS}^2 R$

- **EXAMPLE:** Given a bridge rectifier has an AC source $V_m=100V$ at 50Hz, and R-L load with $R=10\text{ohm}$, $L=10\text{mH}$
 - a) determine the average current in the load
 - b) determine the first two higher order harmonics of the load current
 - c) determine the power absorbed by the load

Controlled full wave, R load

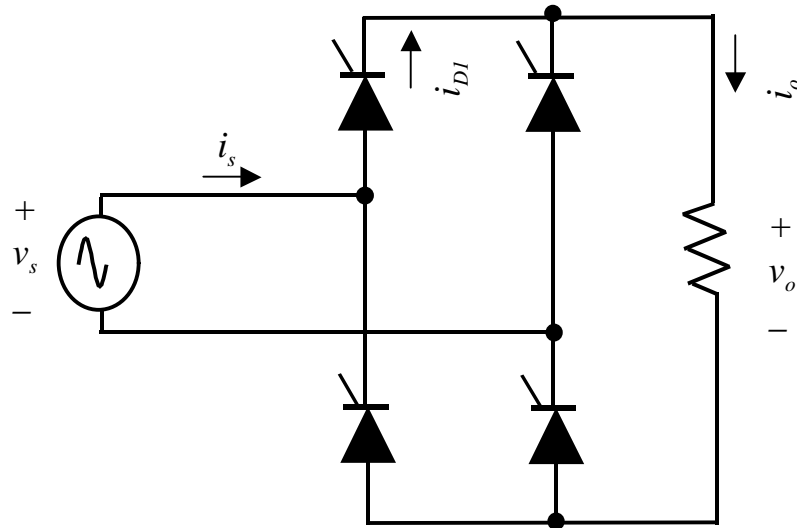

$$V_o = \frac{1}{p} \int_a^p V_m \sin(\omega t) d\omega t = \frac{V_m}{p} [1 + \cos a]$$

$$V_{RMS} = \sqrt{\frac{1}{p} \int_a^p [V_m \sin(\omega t)]^2 d\omega t}$$

$$= V_m \sqrt{\frac{1}{2} - \frac{a}{2p} + \frac{\sin(2a)}{4p}}$$

The power absorbed by the R load is :

$$P_o = \frac{V_{RMS}^2}{R}$$

Controlled, R-L load

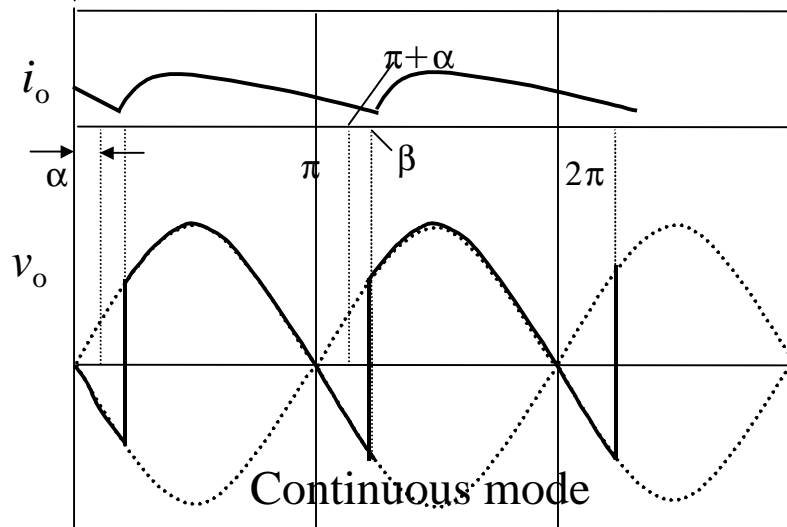
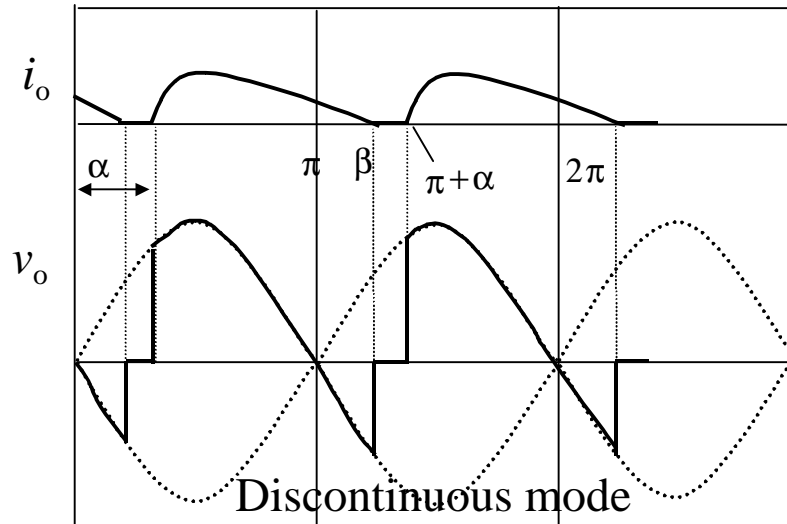
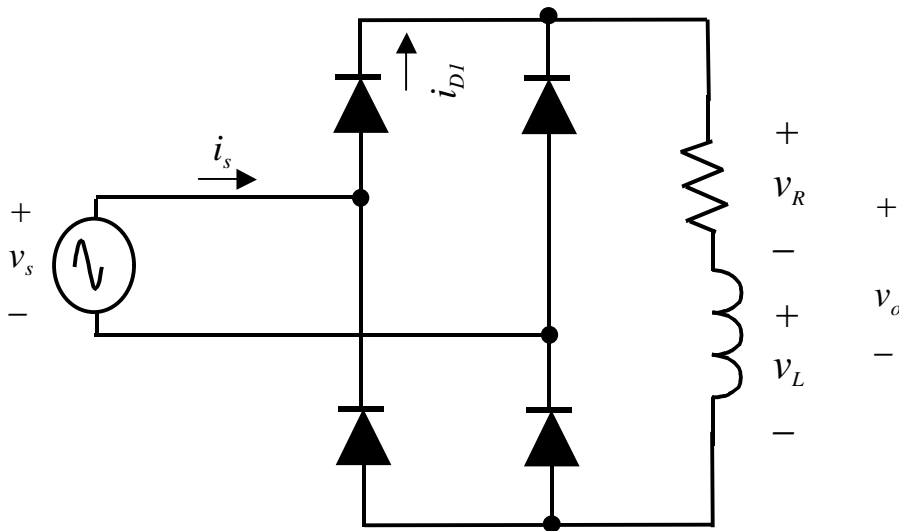

Discontinuous mode

Analysis similar to controlled half wave with R - L load :

$$i(\omega t) = \left(\frac{V_m}{Z} \right) \cdot \left[\sin(\omega t - \phi) - \sin(\alpha - \phi) e^{-(\omega t - \alpha)/\omega \tau} \right]$$

for $\alpha \leq \omega t \leq \beta$

$$Z = \sqrt{R^2 + (\omega L)^2}$$

$$\text{and } \phi = \tan^{-1} \left(\frac{\omega L}{R} \right) ; \tau = \frac{L}{R}$$

For discontinuous mode, need to ensure :

$$\beta < (\alpha + \pi)$$

Note that β is the extinction angle and must be solved numerically with condition :

$$i_o(\beta) = 0$$

The boundary between continuous and discontinuous current mode is when β in the output current expression is $(\pi + \alpha)$.

For continuous operation current at $\omega t = (\pi + \alpha)$ must be greater than zero.

Continuous mode

$$i(p + a) \geq 0$$

$$\sin(p + a - q) - \sin(p + a - q)e^{-(p+a-a)/\omega t} \geq 0$$

Using Trigonometry identity :

$$\sin(p + a - q) = \sin(q - a),$$

$$\sin(q - a)[1 - e^{-(p/\omega t)}] \geq 0,$$

Solving for a

$$a = \tan^{-1}\left(\frac{\omega L}{R}\right)$$

Thus for continuous current mode,

$$a \leq \tan^{-1}\left(\frac{\omega L}{R}\right)$$

Average (DC) output voltage is given as :

$$V_o = \frac{1}{p} \int_a^{a+p} V_m \sin(\omega t) d\omega t = \frac{2V_m}{p} \cos a$$

Single-phase diode groups

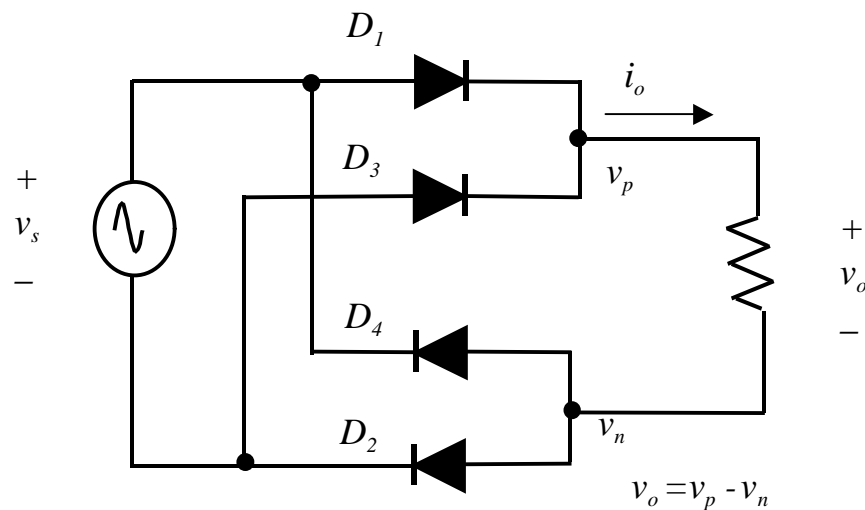

- In the top group (D_1, D_3), the cathodes (-) of the two diodes are at a common potential. Therefore, the diode with its anode (+) at the highest potential will conduct (carry) i_d .
- For example, when v_s is (+), D_1 conducts i_d and D_3 reverses (by taking loop around v_s, D_1 and D_3). When v_s is (-), D_3 conducts, D_1 reverses.
- In the bottom group, the anodes of the two diodes are at common potential. Therefore the diode with its cathode at the lowest potential conducts i_d .
- For example, when v_s (+), D_2 carry i_d . D_4 reverses. When v_s is (-), D_4 carry i_d . D_2 reverses.

Three-phase rectifiers

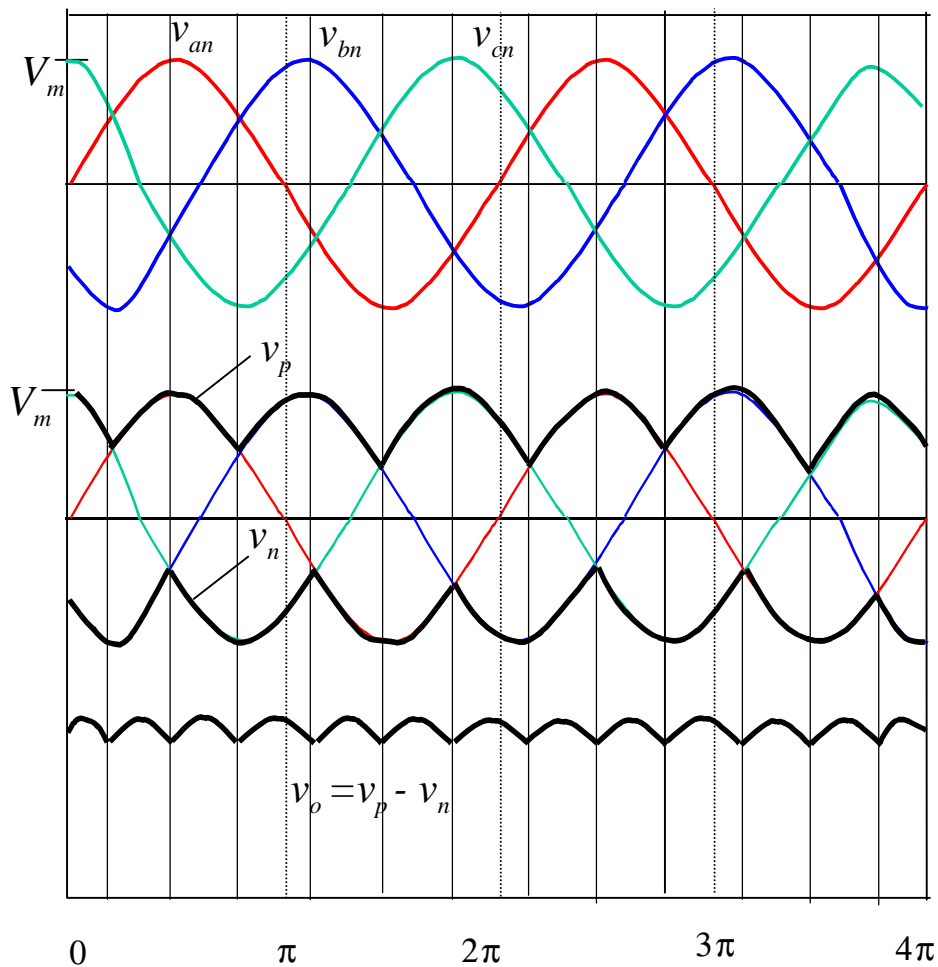
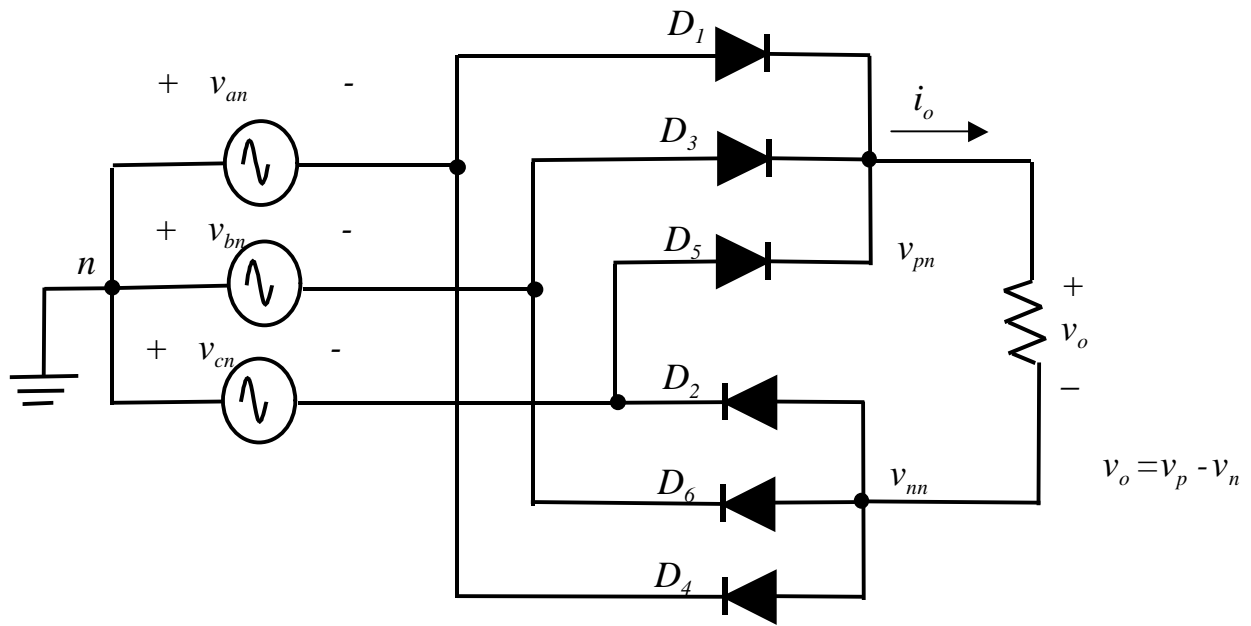

Three-phase waveforms

- Top group: diode with its anode at the highest potential will conduct. The other two will be reversed.
- Bottom group: diode with the its cathode at the lowest potential will conduct. The other two will be reversed.
- For example, if D_1 (of the top group) conducts, v_p is connected to v_{an} . If D_6 (of the bottom group) conducts, v_n connects to v_{bn} . All other diodes are off.
- The resulting output waveform is given as:
$$v_o = v_p - v_n$$
- For peak of the output voltage is equal to the peak of the line to line voltage v_{ab} .

Three-phase, average voltage

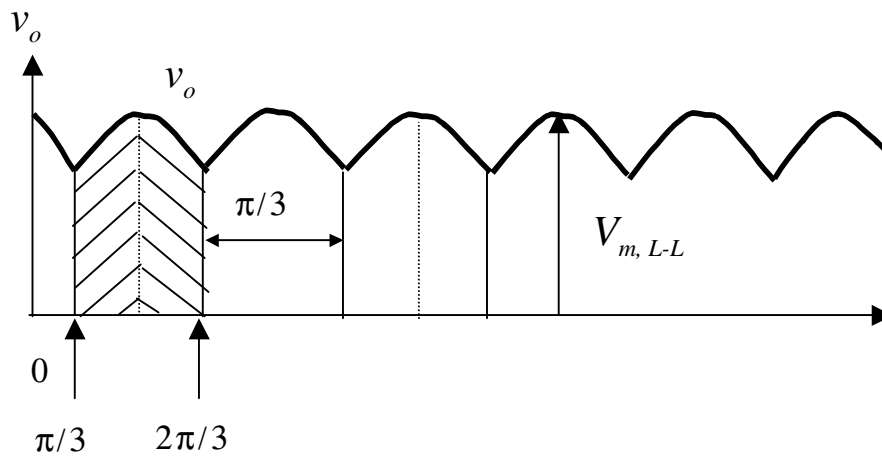

Considers only one of the six segments. Obtain its average over 60 degrees or $\pi/3$ radians.

Average voltage :

$$\begin{aligned}
 V_o &= \frac{1}{\pi/3} \int_{\pi/3}^{2\pi/3} V_{m,L-L} \sin(\omega t) d\omega t \\
 &= \frac{3V_{m,L-L}}{\pi} [\cos(\omega t)]_{\pi/3}^{2\pi/3} \\
 &= \frac{3V_{m,L-L}}{\pi} = 0.955V_{m,L-L}
 \end{aligned}$$

Note that the output DC voltage component of a three - phase rectifier is much higher than of a single - phase.

Controlled, three-phase

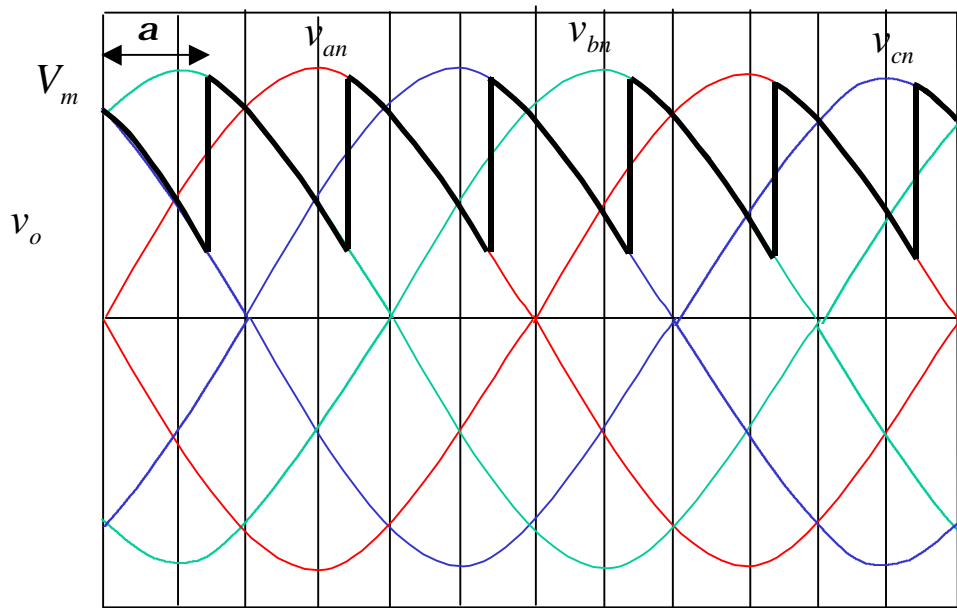
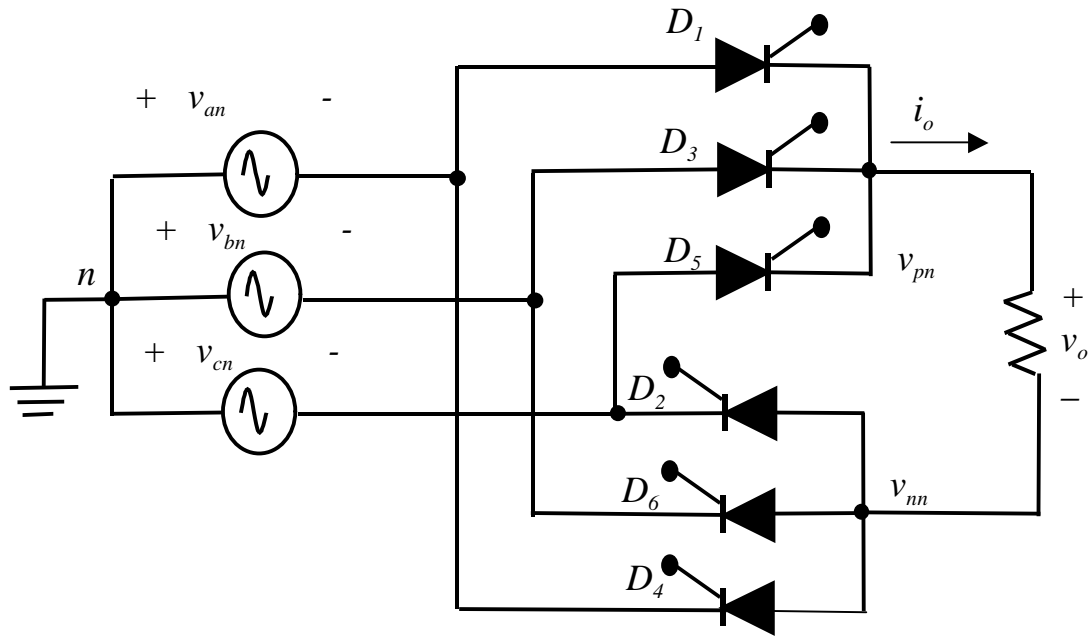

Output voltage of controlled three phase rectifier

From the previous Figure, let α be the delay angle of the SCR.

Average voltage can be computed as :

$$V_o = \frac{1}{\pi/3} \int_{\pi/3+\alpha}^{2\pi/3+\alpha} V_{m,L-L} \sin(\omega t) d\omega t$$
$$= \left(\frac{3V_{m,L-L}}{\pi} \right) \cdot \cos \alpha$$

- **EXAMPLE:** A three-phase controlled rectifier has an input voltage of 415V RMS at 50Hz. The load $R=10$ ohm. Determine the delay angle required to produce current of 50A.