



---

# EE 353 Power Electronics

WS 1999

# Definition

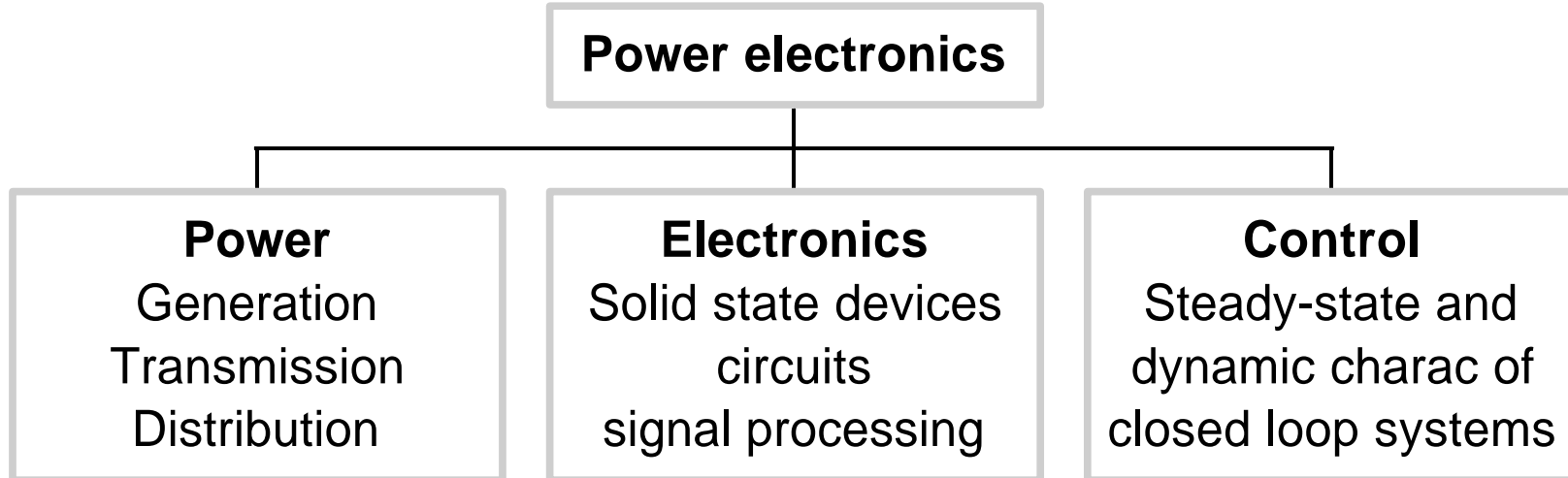

# Power Electronics Systems

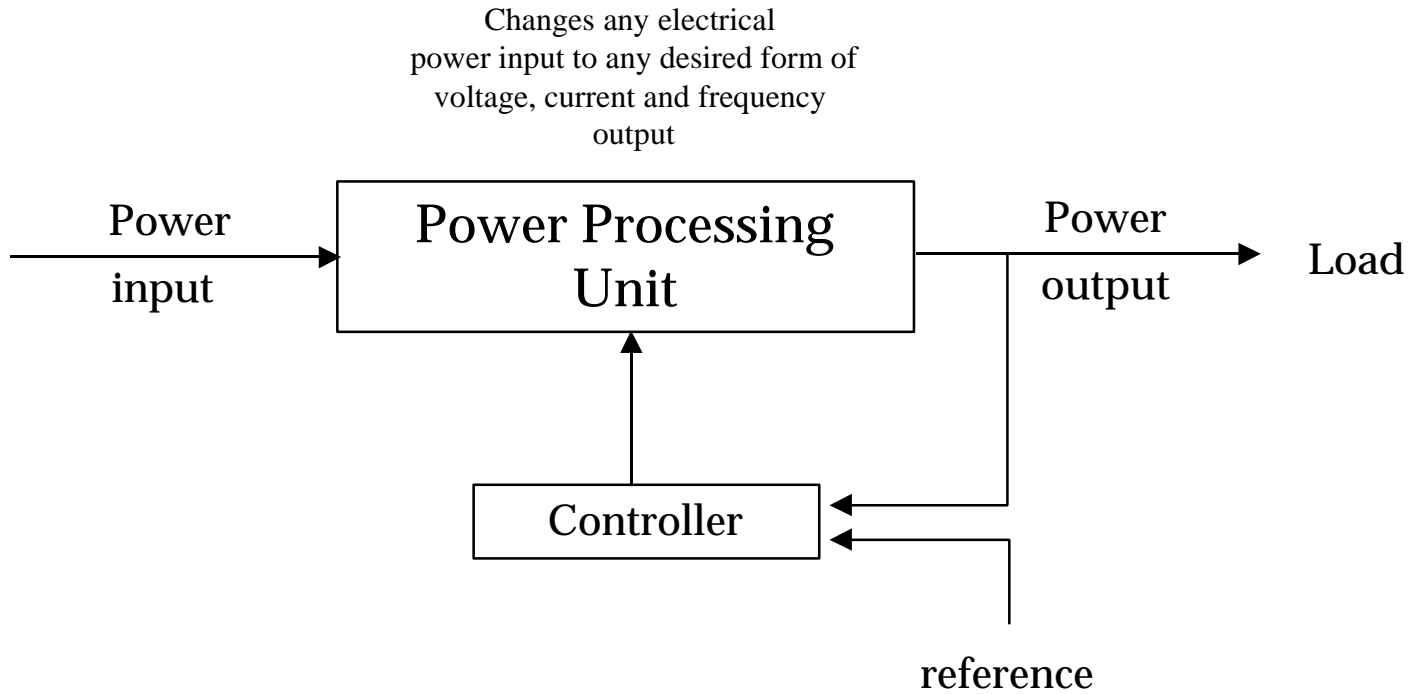

# Power Processor Example

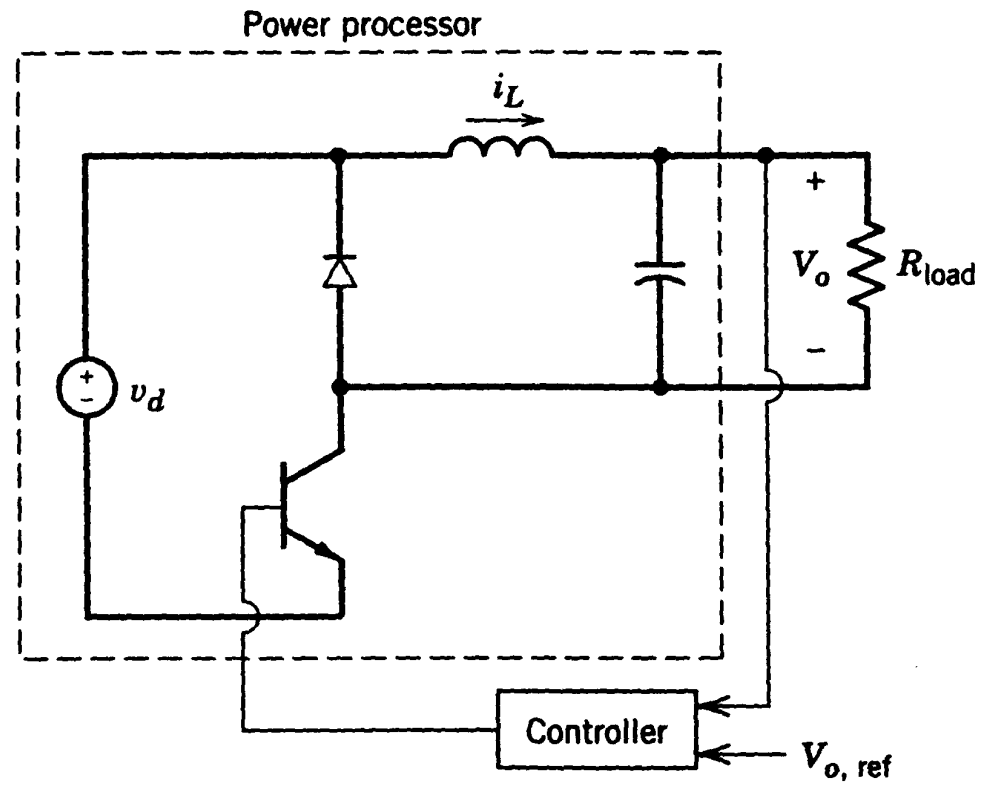

# Power Processor Eqvt. Ckt.

$$V_o = \frac{1}{T_s} \int_0^{T_s} v_{oi} dt = \frac{t_{on}}{T_s} v_d$$

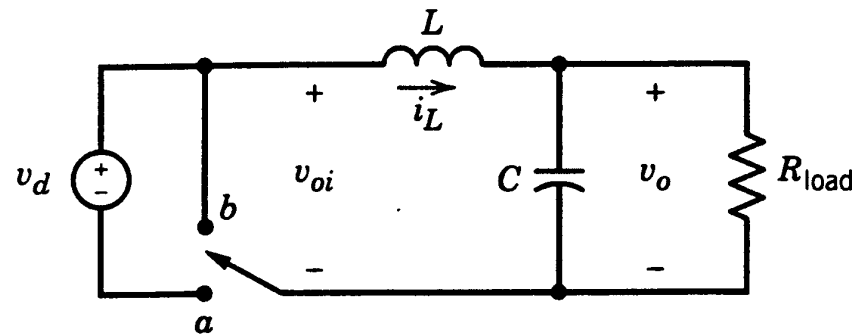

(a)

# Waveforms

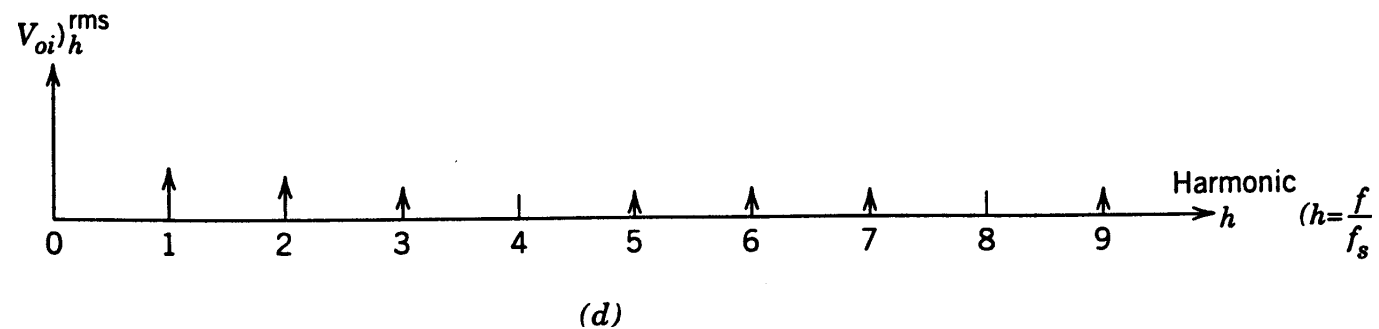
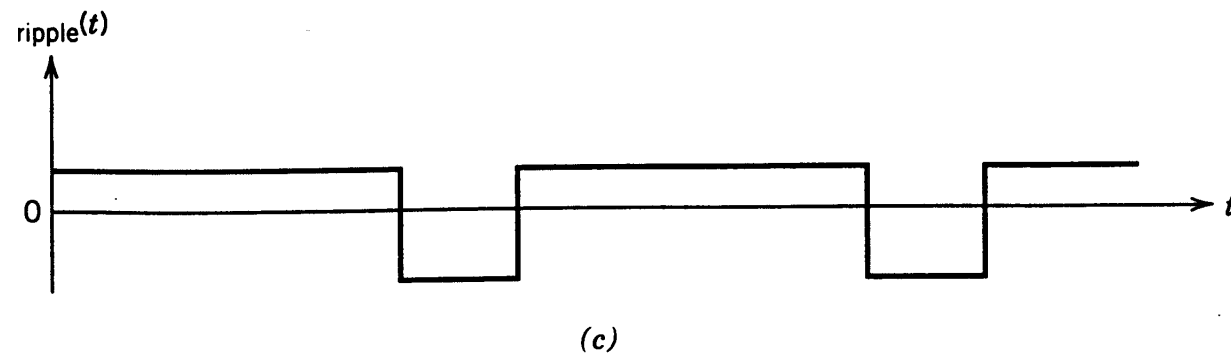
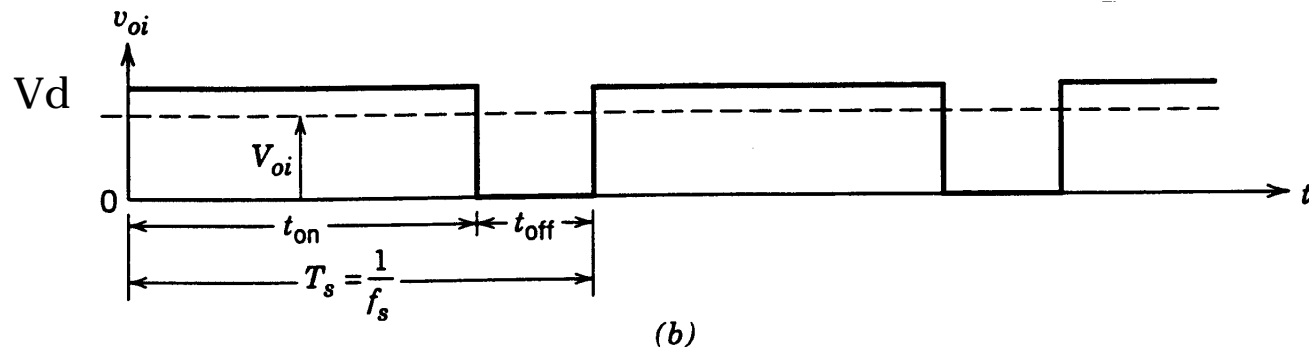

# Converters

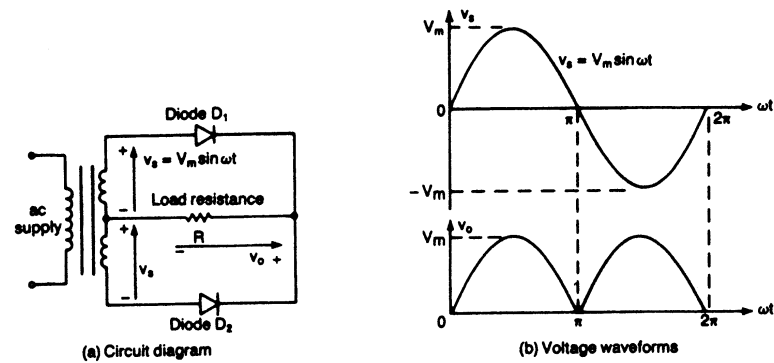

Figure 1-8 Single-phase rectifier circuit.

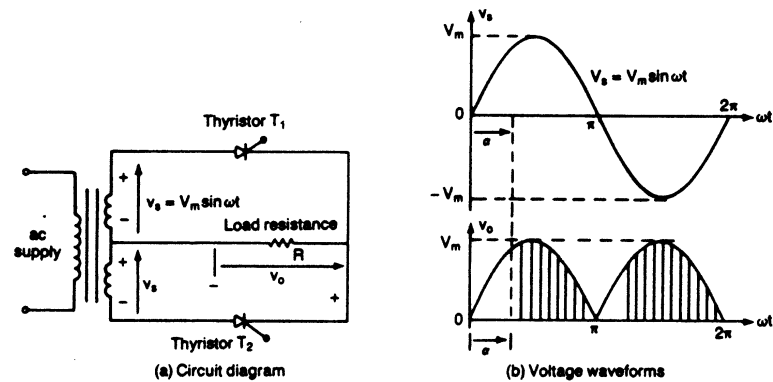

Figure 1-9 Single-phase ac-dc converter.

# Converters, cont'd

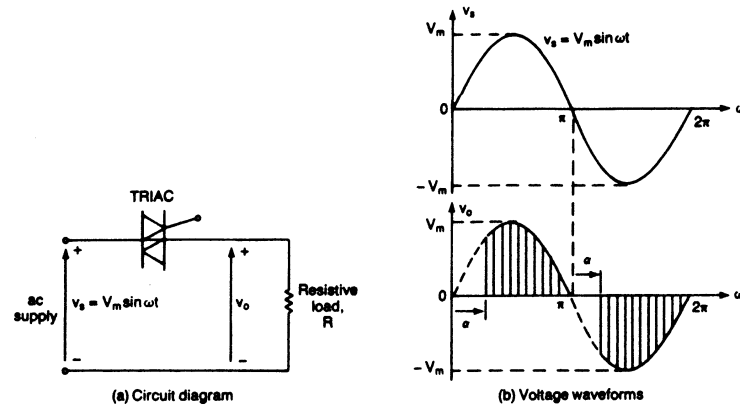

Figure 1-10 Single-phase ac-ac converter.

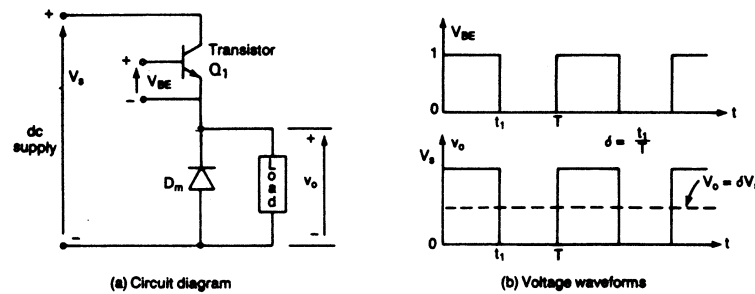

Figure 1-11 Dc-dc converter.

# Converters, cont'd

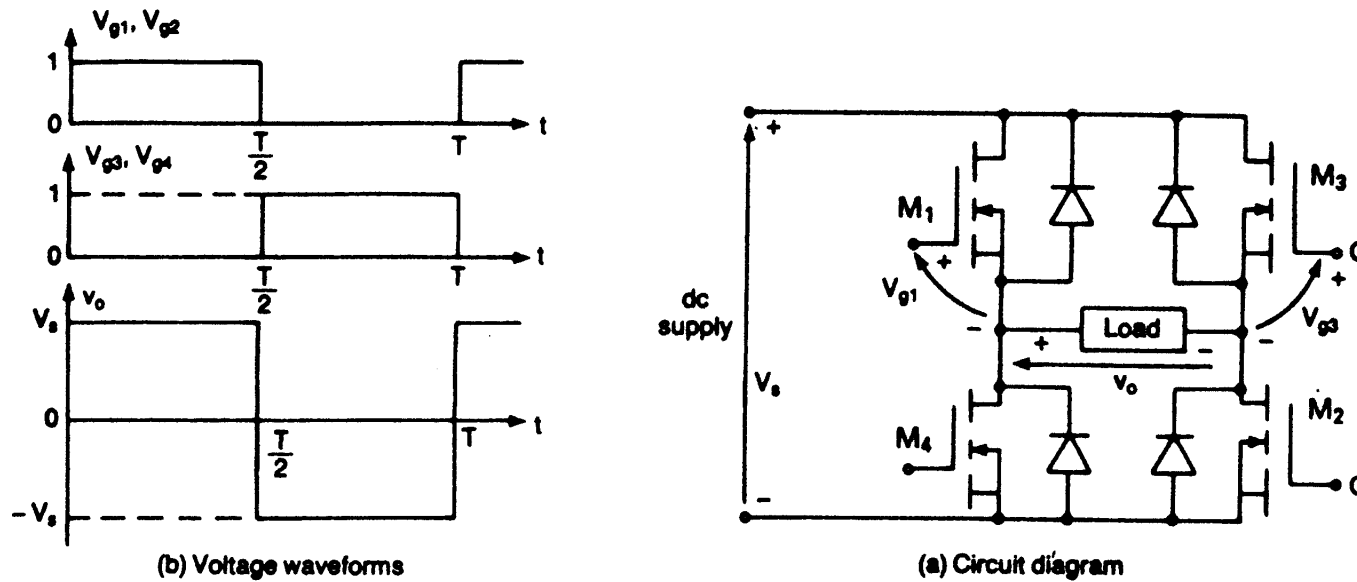
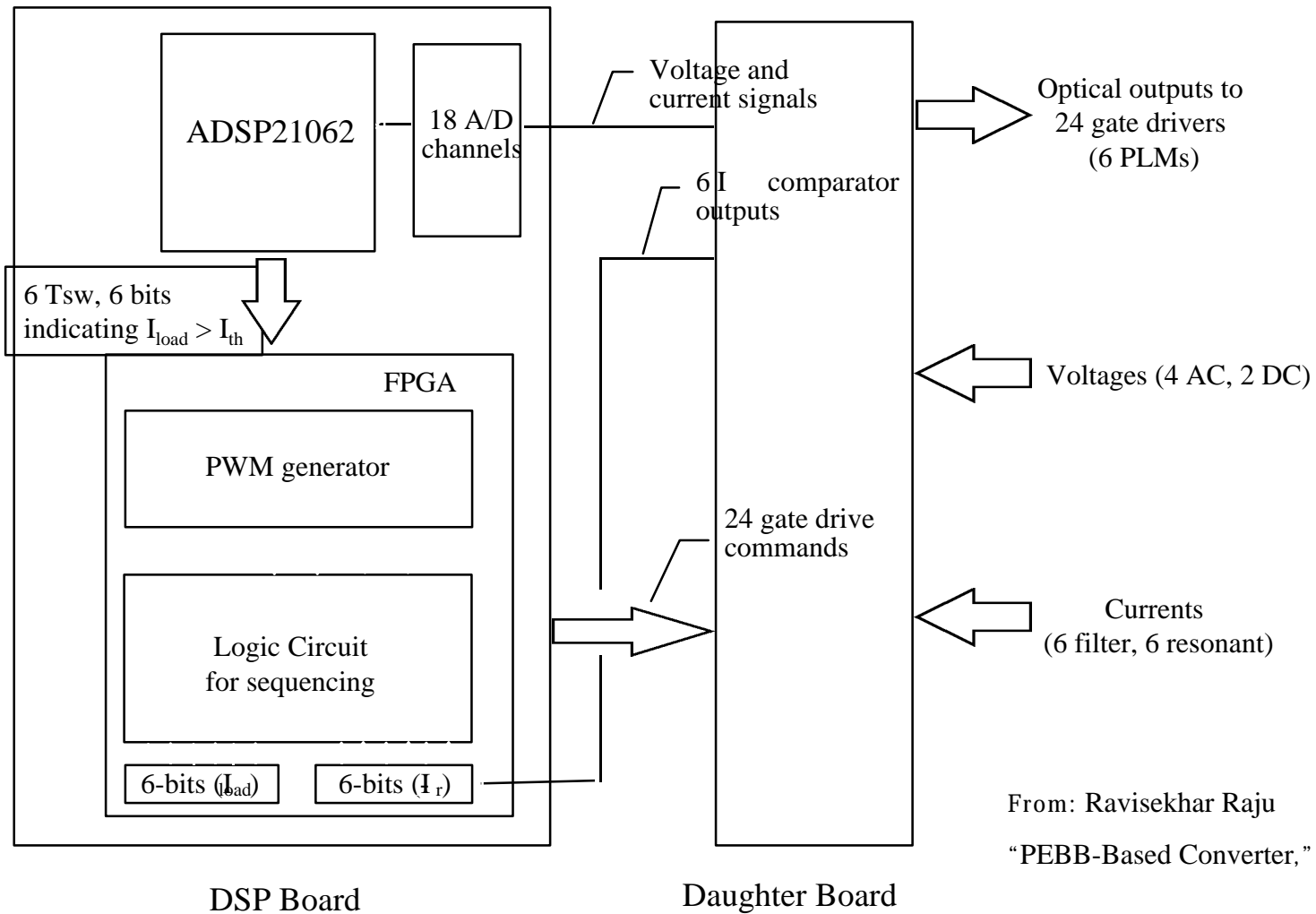

Figure 1-12 Single-phase dc-ac converter.

# Converter Control Schematic Example



# Brief History

---

---

- 1900 - Mercury arc rectifier
- 1948 - Silicon transistor (Bell Labs)
- 1956 - Silicon Controlled Rectifier (Bell)
- 1958 - Thyristor (General Electric)

# History

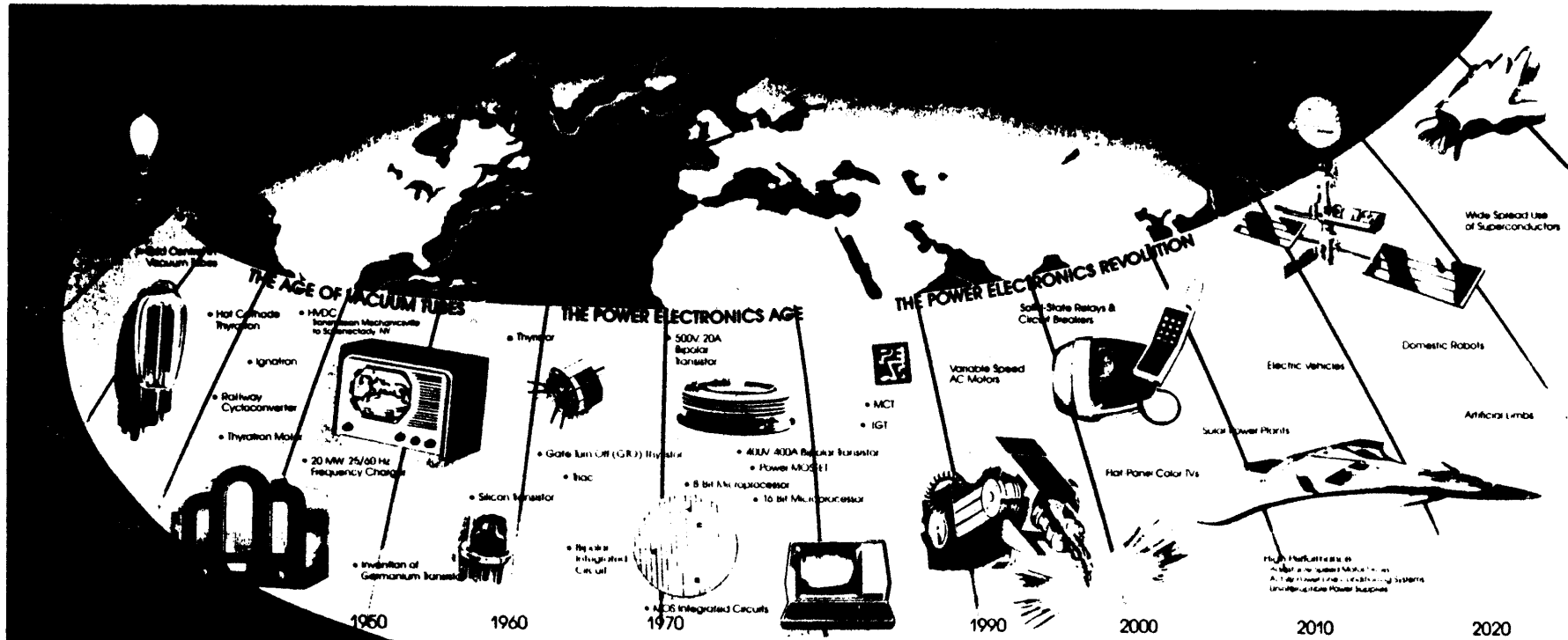
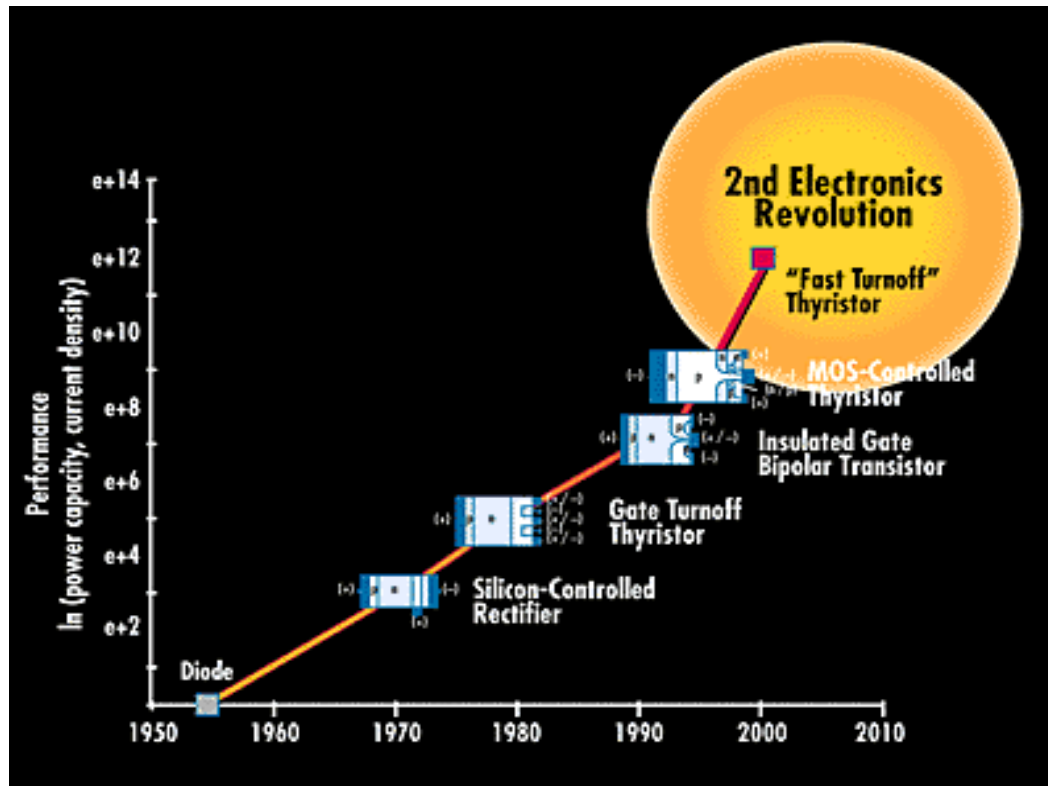

Figure 1-2 , History of power electronics. (Courtesy of Tennessee Center for Research and Development.)

# The Second Revolution



# Power Semiconductor devices

The muscle for power electronic equipment









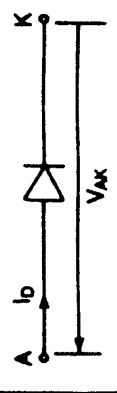
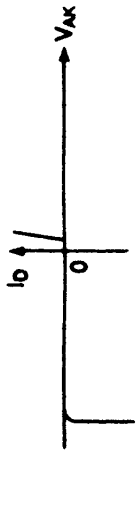
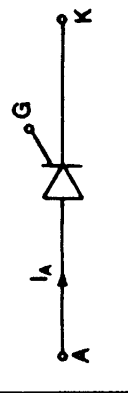
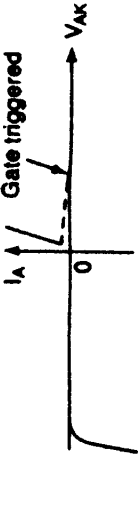

- Power diodes
- Thyristors
- Power bipolar junction transistor (BJT)
- Power MOSFET
- IGBT
- Static induction transistor
- MCT, GTO, MTO

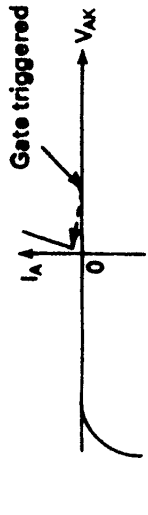
# Device Ratings

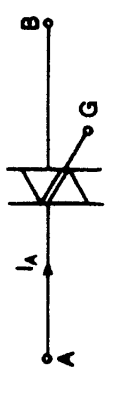
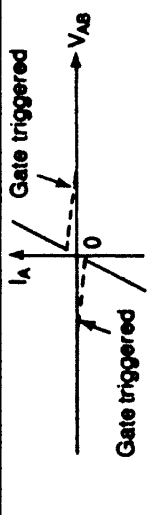
**TABLE 1.2 RATINGS OF POWER SEMICONDUCTOR DEVICES**

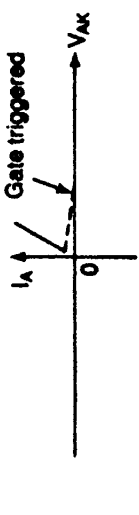
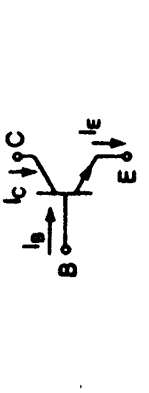
Type		Voltage/current rating	Upper frequency (Hz)	Switching time ( $\mu$ s)	On-state resistance ( $\Omega$ )
Diodes	General purpose	5000 V/5000 A	1k	100	0.16m
	High speed	3000 V/1000 A	10k	2-5	1m
	Schottky	40 V/60 A	20k	0.23	10m
Forced-turned-off thyristors	Reverse blocking	5000 V/5000 A	1k	200	0.25m
	High speed	1200 V/1500 A	10k	20	0.47m
	Reverse blocking	2500 V/400 A	5k	40	2.16m
	Reverse conducting	2500 V/1000 A	5k	40	2.1m
	GATT	1200 V/400 A	20k	8	2.24m
	Light triggered	6000 V/1500 A	400	200-400	0.53m
TRIACs		1200 V/300 A	400	200-400	3.57m
Self-turned-off thyristors	GTO	4500 V/3000 A	10k	15	2.5m
	SITH	4000 V/2200 A	20k	6.5	5.75m
Power transistors	Single	400 V/250 A	20k	9	4m
		400 V/40 A	20k	6	31m
		630 V/50 A	25k	1.7	15m
		1200 V/400 A	10k	30	10m
	Darlington	1200 V/300 A	100k	0.55	1.2
SITs		1200 V/300 A	100k	0.55	1.2
Power MOSFETS	Single	500 V/8.6 A	100k	0.7	0.6
		1000 V/4.7 A	100k	0.9	2
		500 V/50 A	100k	0.6	0.4m
		1200 V/400 A	20k	2.3	60m
IGBTs	Single	1200 V/400 A	20k	2.3	60m
MCTs	Single	600 V/60 A	20k	2.2	18m

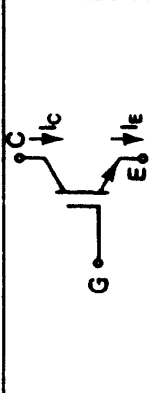
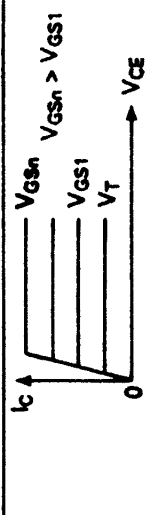
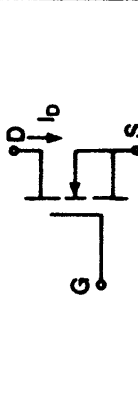
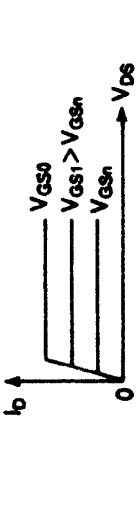
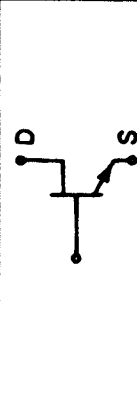
TABLE 1.3 CHARACTERISTICS AND SYMBOLS OF SOME POWER DEVICES

Devices	Symbols	Characteristics
Diode		
Thyristor		
SITH		
GTO		
MCT		
TRIAC		
LASCR		
NPN BJT		
IGBT		
N-Channel MOSFET		
SIT		

# Power Electronics Applications

## Transportation Industry

- Electric Vehicles
- Electric Locomotives
- Electric Trucks, Buses, Construction Vehicles

## Utilities

- Line Transformers
- Generating Systems

## Manufacturing

- Machinery
- Power Systems

## Consumers

- Air Conditioners/Heat Pumps
- Appliance

## Medical Equipment

## Government

### Naval Systems

- Ship Power Systems
- New Surface Ship Power Electronics
- New Submarine Power Electronics

### Aviation Systems

- "More Electric" Aircraft

### Land Based Systems

- "All Electric Tank"
- "All Electric Armored personnel Carrier"

# Specific Applications

## POWER SYSTEM APPLICATIONS

- Intelligent Machinery Controls & Network Simulation
- Solid State Power Conditioning & Circuit Protection
- Motors, Generators, & Motor Drives
- Actuators and Actuator Drives
- Energy Storage
- Pulse Power Systems
- Power Conversion - inverters for renewables, HVDC
- FACTS devices

## CONTROL APPLICATIONS

- Frequency Changes
- Motor Controllers
- Adjustable Speed Drives
- Inverters
- Rectifiers
- Converters
- Power Supplies
- Battery Chargers
- Switch Gear
- Breakers

# Conventional vs EV

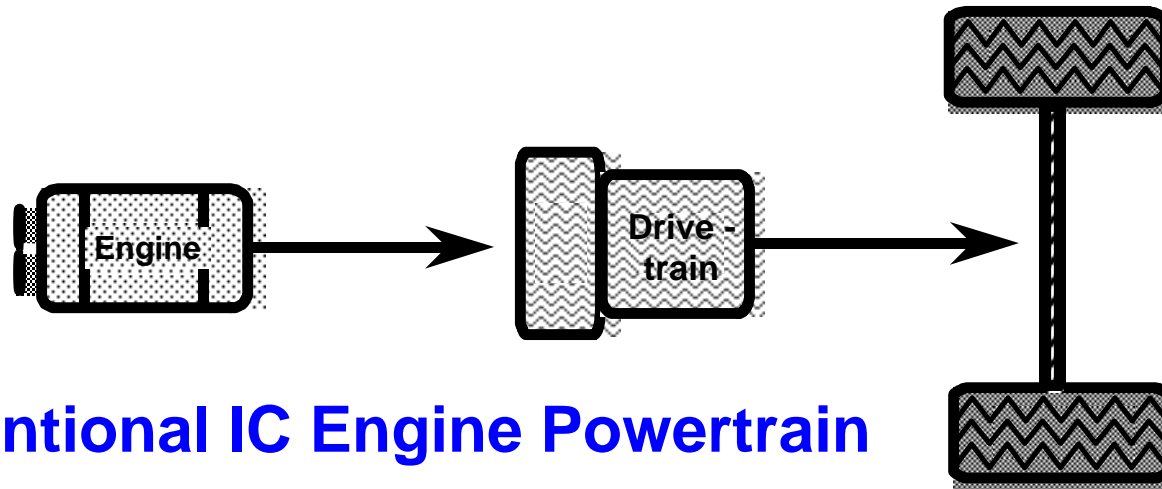

**Conventional IC Engine Powertrain**

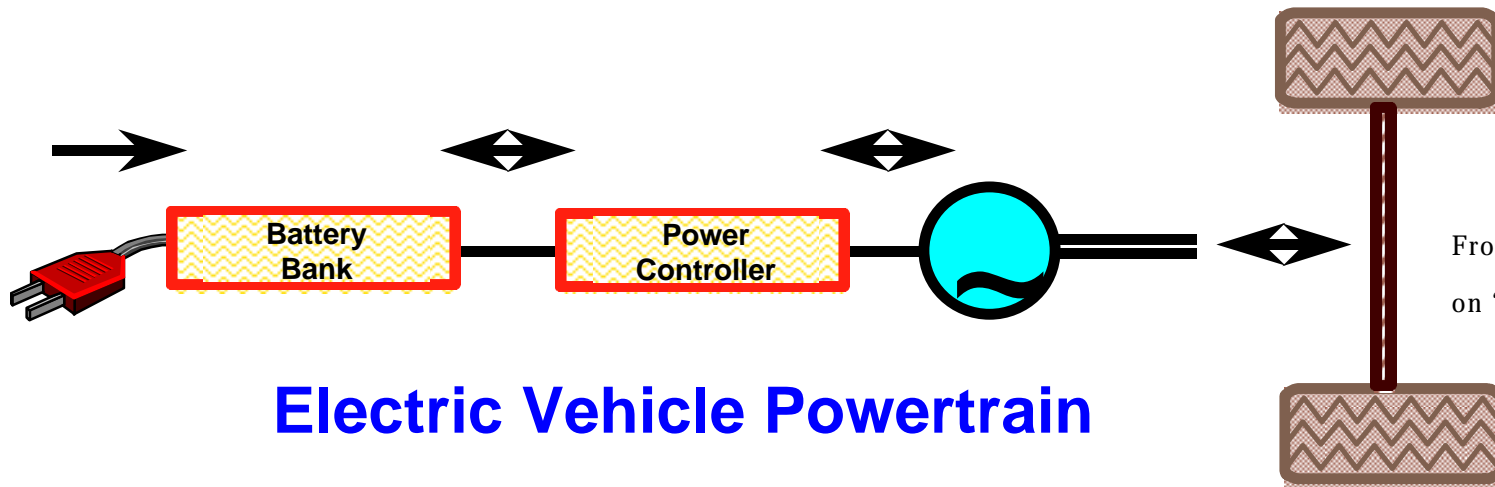

**Electric Vehicle Powertrain**

From: Chrysler presentation on "Hybrid Electric Vehicles"

# “More Electric Aircraft” - USAF

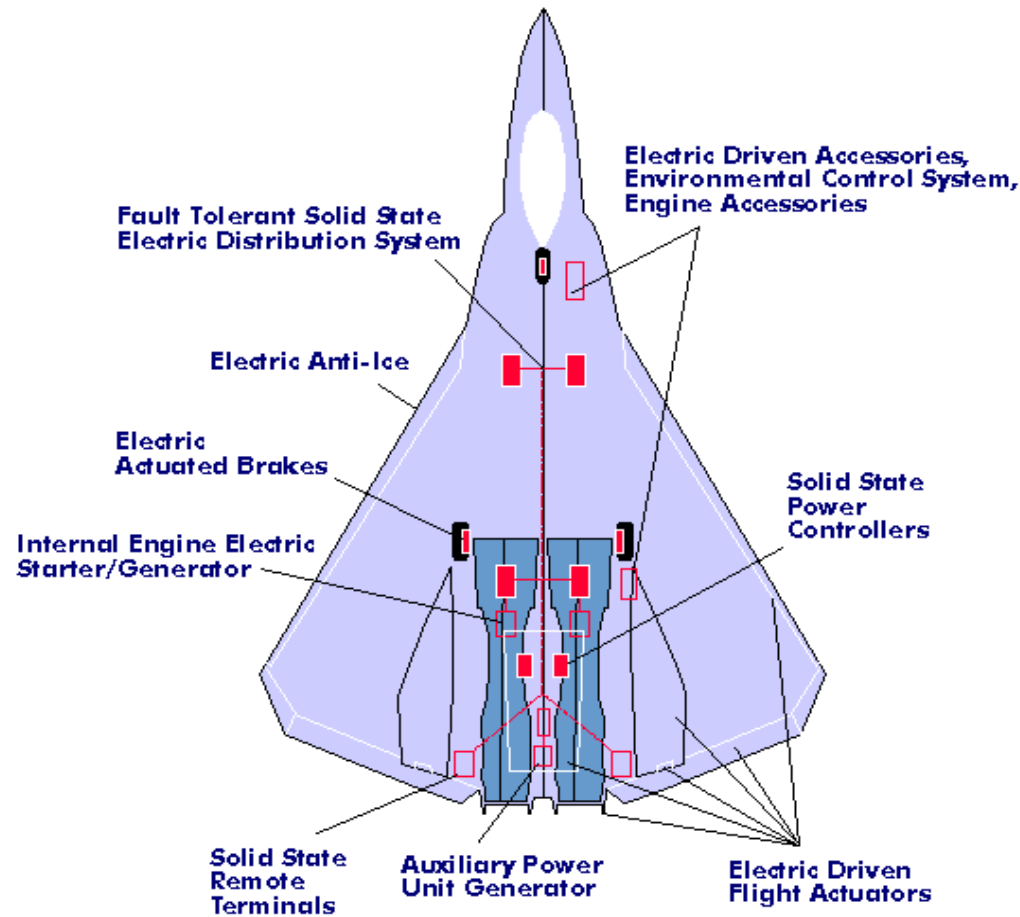

The More Electric Aircraft initiative intelligently applies new, innovative, electrically-driven smart power subsystem technologies for aircraft secondary power which traditionally use hydraulic, pneumatic, mechanical and electrical components.

# Shipboard Power System - USNavy

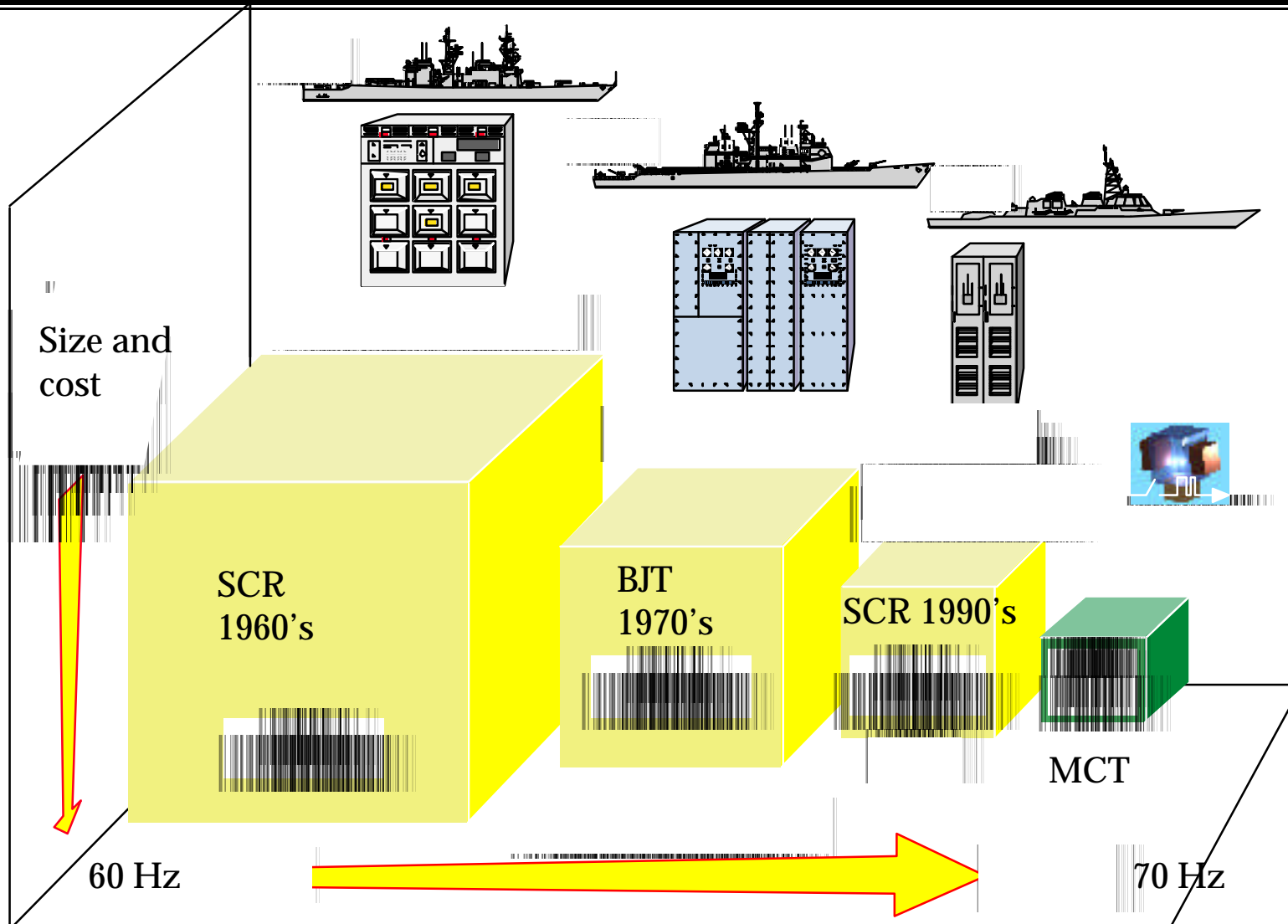

# Submarine Power System - USNavy

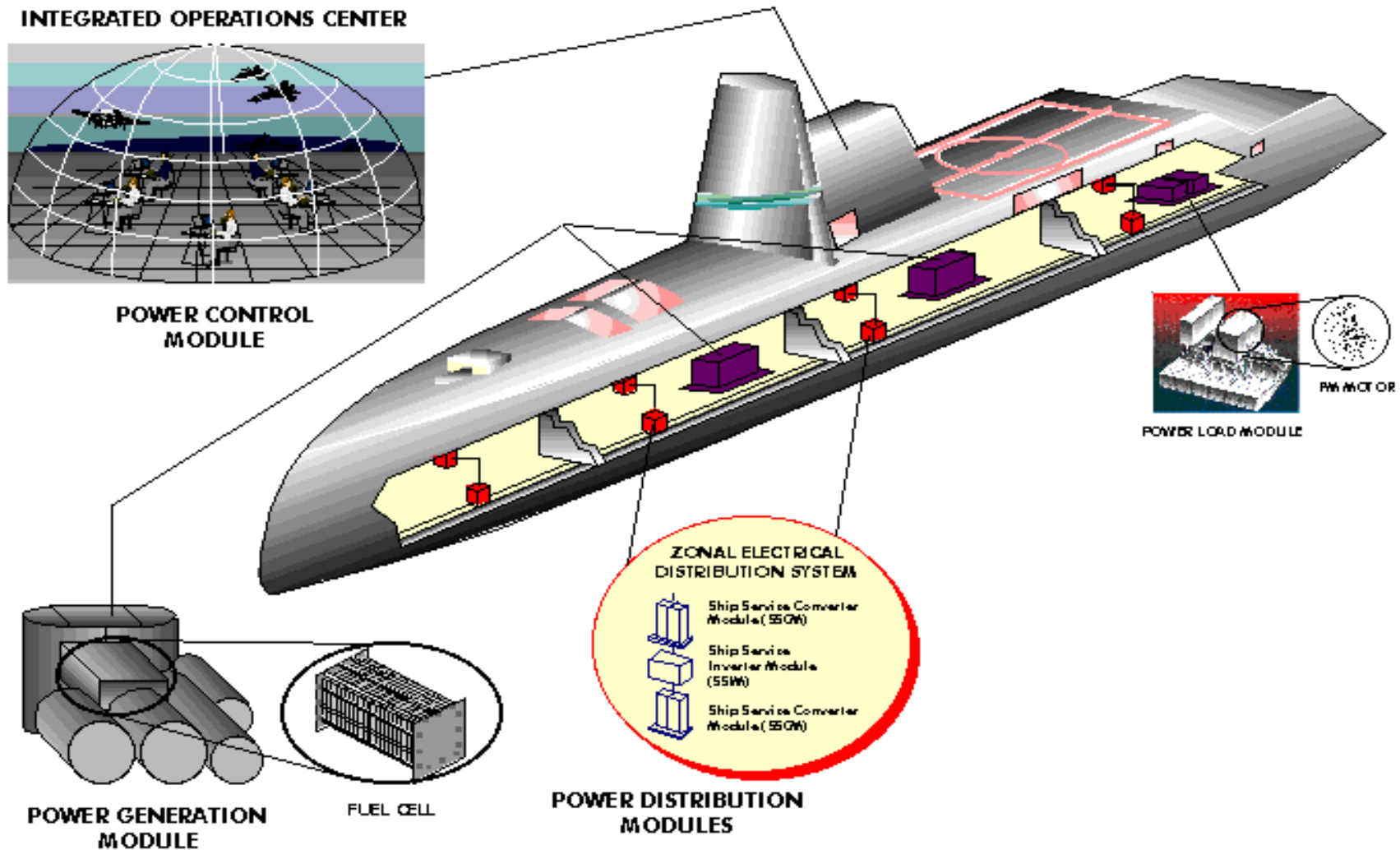

# "All Electric Armored personnel Carrier" - USARMY



# Power Electronic Building Blocks - ONR

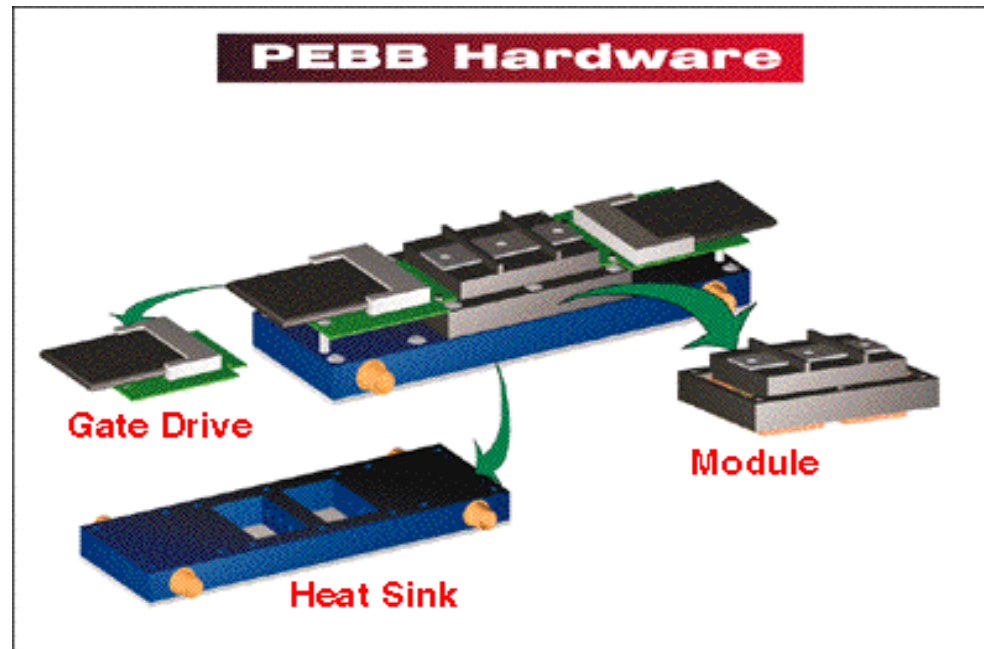

# PEBB-Based Power System

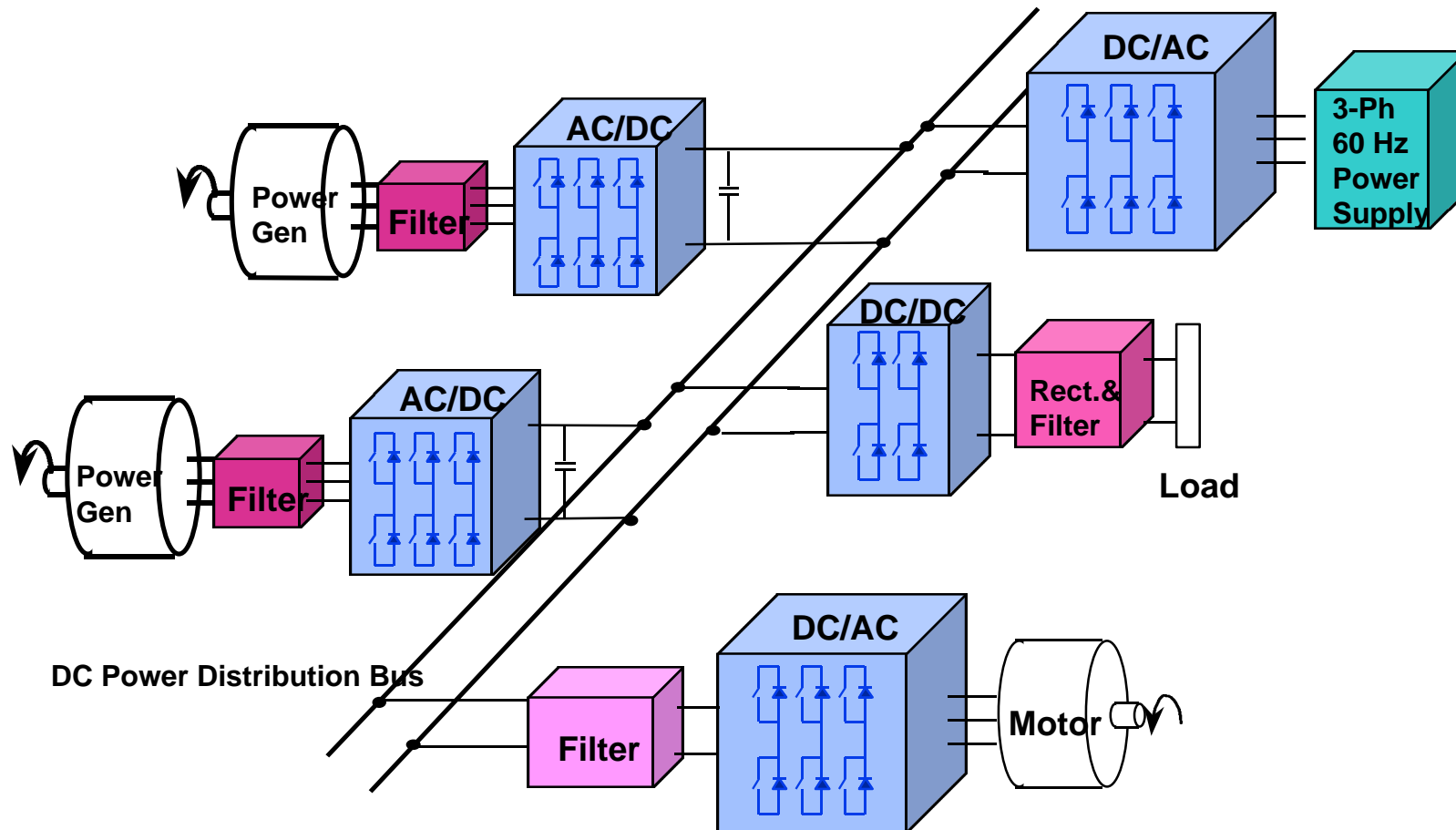

From: Fred. C. Lee, Dusan Borjevic

“Power Electronics Building Blocks,” VPI



---

# Applications in Power Transmission

# Application - HVDC Transmission



[1] A set of three quadruple thyristor-based valves feeds each of the three dc poles [the third is barely seen at the right] in this valve hall. The equipment serves India's 910-km, 1500-MW high-voltage dc link. First operated in 1991, the link ties coal-based power plants in Rihand, in the eastern part of India, to Delhi's fast-growing load farther west.

PHOTO: ABB

# Application - Back-to-Back Tie



[2] A 600-MW back-to-back HVDC tie between the Welsh and Monticello power plants connects the Texas electric power system to the Eastern U.S. system. The different frequency controls of the two systems make it impossible to connect them otherwise. Both converters (for ac to dc or vice versa) are at the same location, with a dc busbar connecting them. A large outdoor area is occupied by harmonic filters, capacitors, switching gear, and other equipment.

PHOTO: SIEMENS ENERGY & AUTOMATION INC.

# Thyristor-Controlled Series Comp.

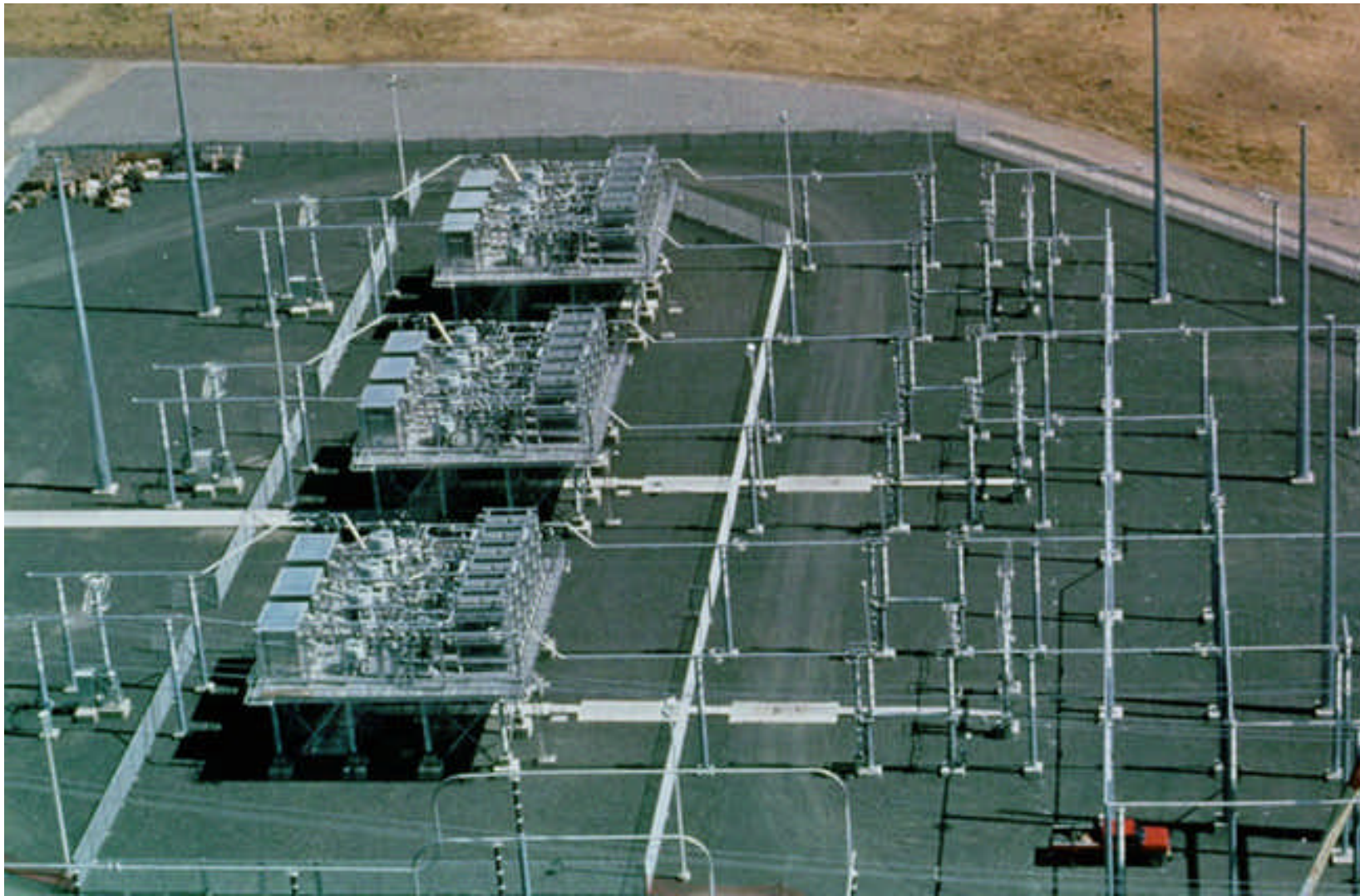

# Gate Turn-Off Thyristor

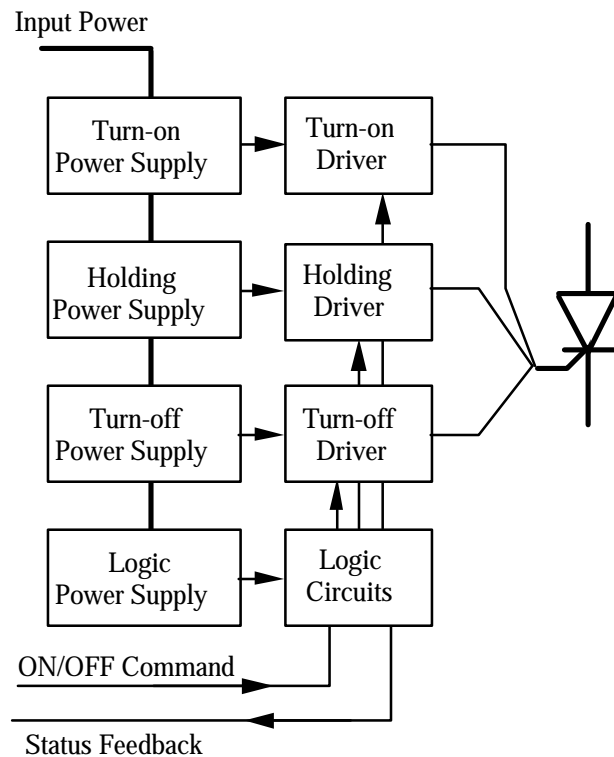

From: R.W. De Doncker

“High Power Electronic Building Blocks (HPEBBs),” Si Power Corp. (SPCO)

# New Devices/Materials

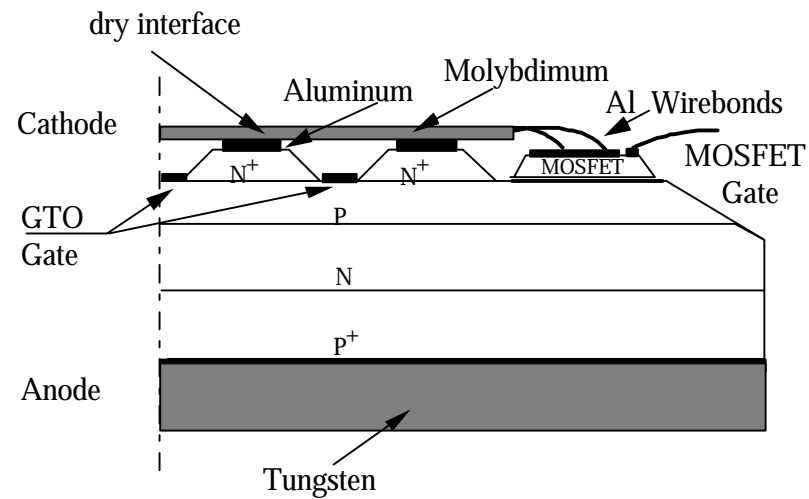
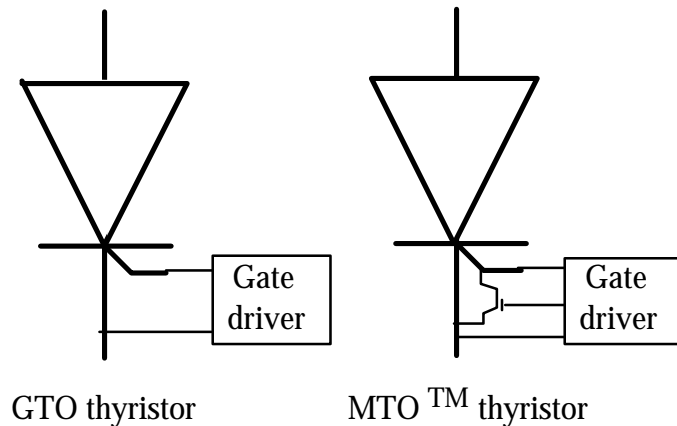

- MTO devices use same manufacturing technology as GTOs
- MTO devices reach same ratings as GTOs but offer lower turn-off losses

From: R.W. De Doncker

“High Power Electronic Building Blocks (HPEBBs),” Si Power Corp. (SPCO)

# New Devices/Materials

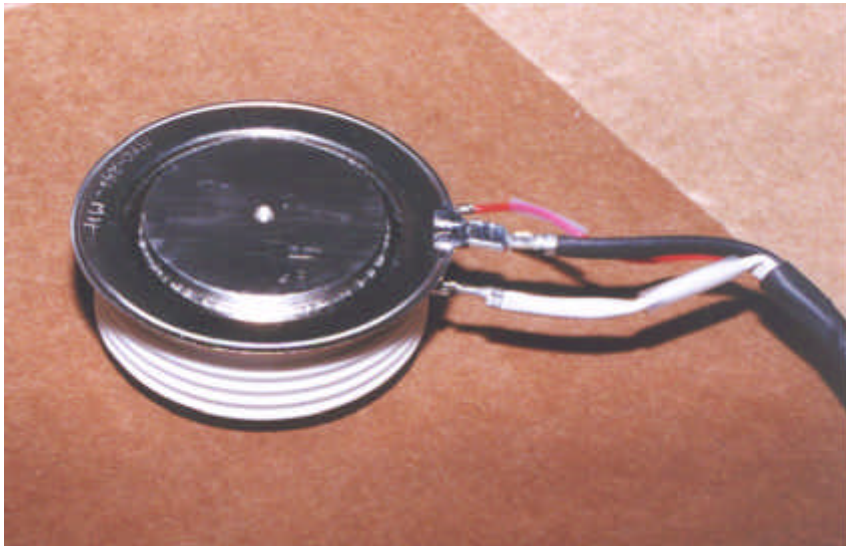

53mm 4.5 kV MTOs

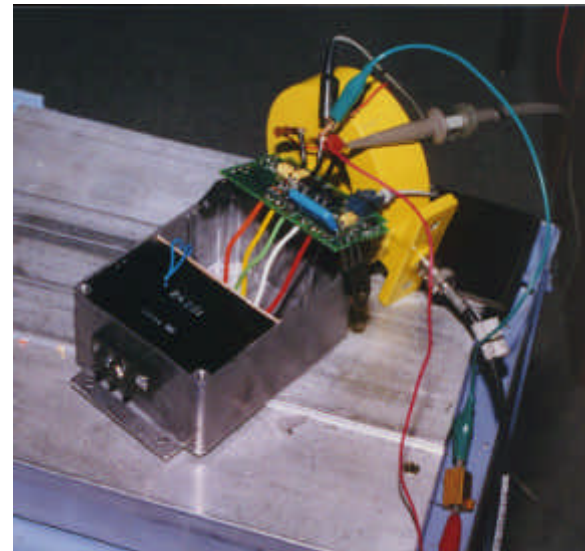

MTO gate drivers

From: Ravisekhar Raju

“PEBB-Based Converter,” Si Power Corp.

# New Devices/Materials

---

---

- Innovative silicon concepts and newly identified non-silicon materials, including silicon carbide (SiC), diamond, and Group III nitrides, promise new generations of electronic devices operational at much higher voltages and switching frequencies, resulting in high-power systems with lower cost, greater reliability, and reduced size, weight, and cooling needs.
- The market for high-power electronics is worth billions over the next decade.

# Gate Driver for IGBT Modules

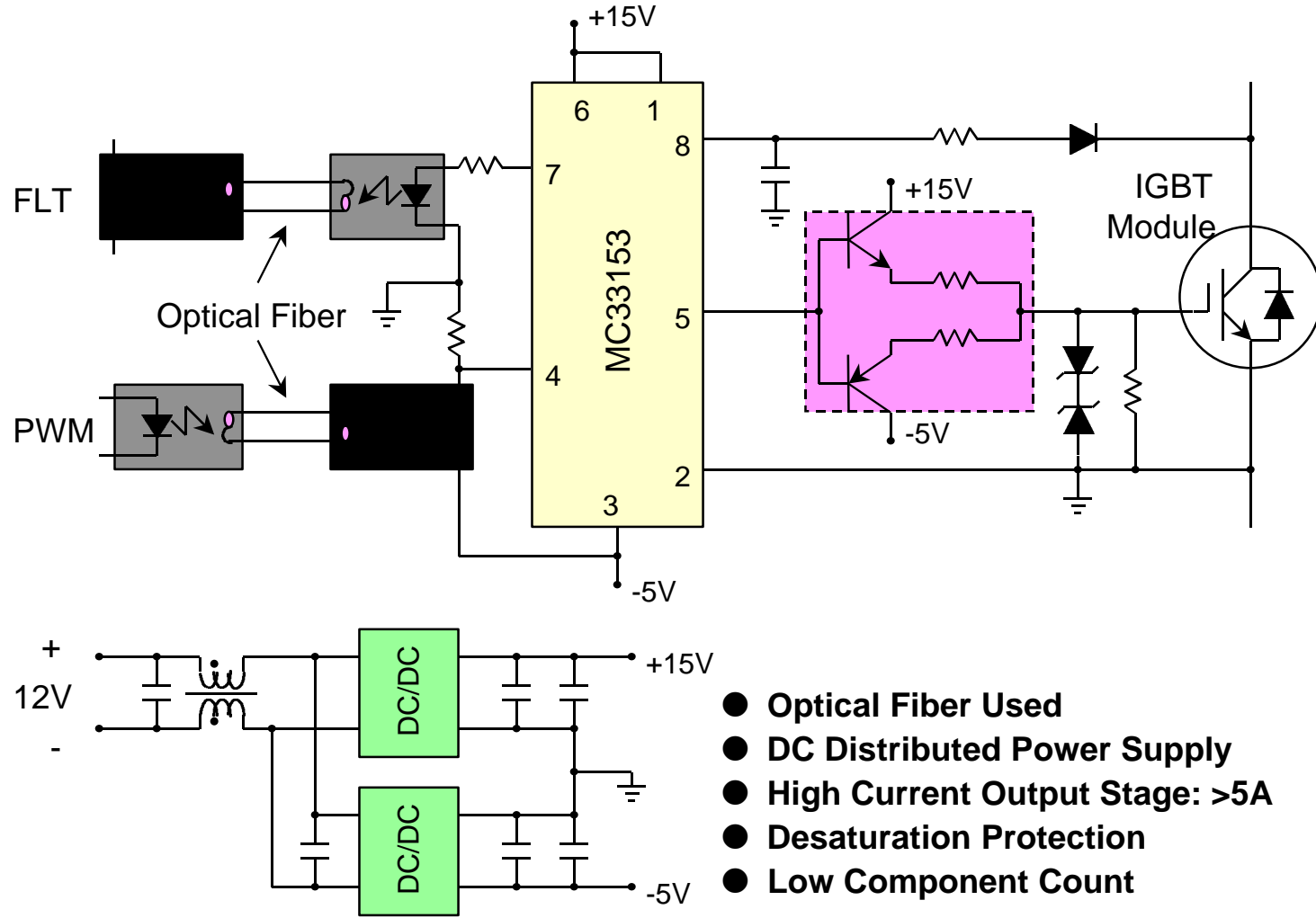

# Gate Driver Mounted On IGBT Module

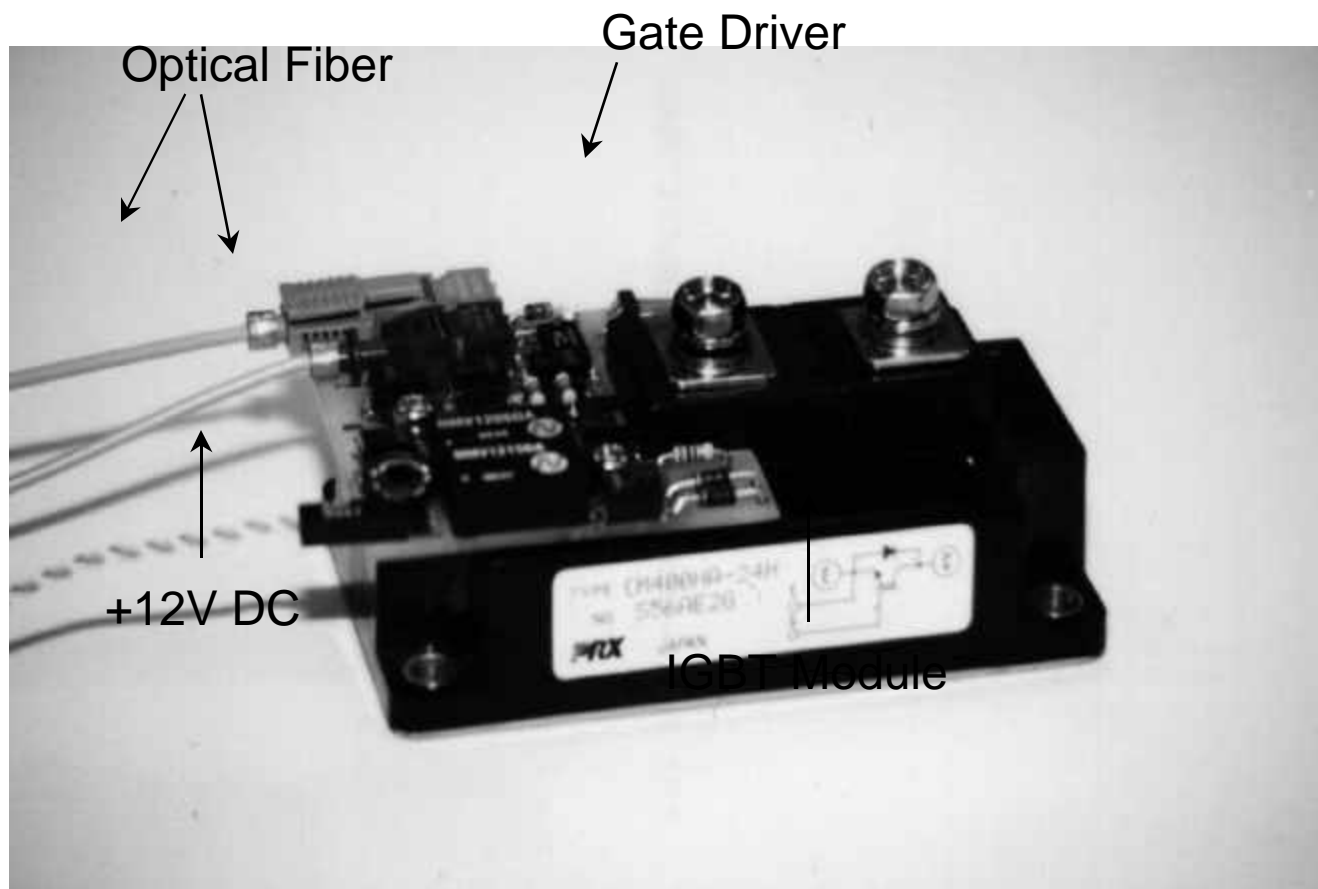

# Switched Reluctance Motor

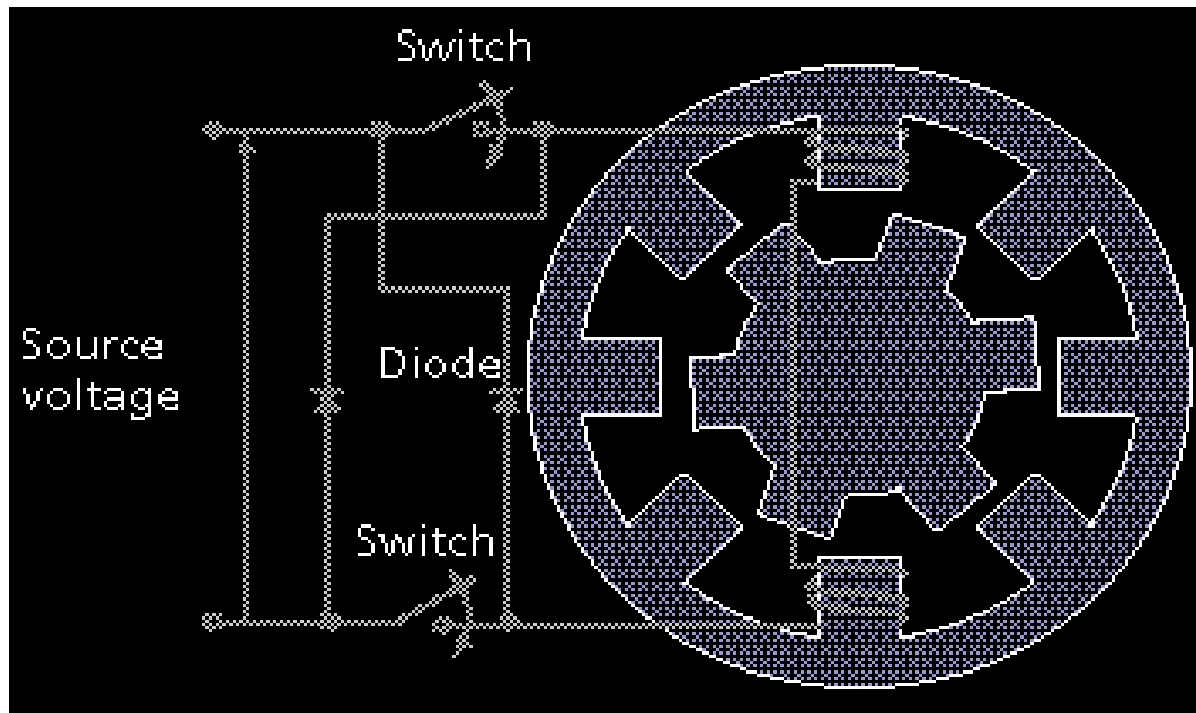

The switched reluctance motor is diagrammed as a simplified eight-pole stator and a six-pole rotor machine. Torque is developed by the tendency of a magnetic circuit to adopt a configuration of minimum reluctance (to maximize the magnetic flux). This tendency translates into a rotation of the rotor so that its poles align with the stator's poles. These pole pairs are in turn energized sequentially from a dc source through electronic switches, thereby creating the rotating torque.

# Selected Companies

---

---

- Vicor Corp., Andover, Mass.
- Delco Electronics, Torrance, Calif.
- Harris Semiconductor Corp., Mountaintop, PA
- Halmar Robicon, Pittsburgh
- ABB
- Siemens AG
- Motorola Inc. Semiconductor Products, Phoenix, Ariz.
- International Rectifier Corp., El Segundo, CA
- GE
- Westinghouse
- Toshiba America Electronic Components Inc., Irvine, CA

# Companies, cont'd

- Mitsubishi Electric Corp.
- Powerex
- Emerson Motor Co., St Louis, MO
- Magna Physics Division of Tridelta Industries Inc., Mentor, OH
- Cutler-Hammer, Milwaukee, WI
- IBM
- Silicon Power Corp.
- Northrup-Grumman Corp.
- Analog Devices, Norwood, MA
- Allen-Bradley