

CHAPTER V

Motor Drives

- Motor drive systems definitions
- Review of motor principles
- Mechanical Requirements of Motor Drives

Electric Motor Drives

- **DEFINITION:** Electric drives for motor is used to draw electrical energy from the mains and supply the electrical energy to the motor at whatever voltage, current and frequency necessary to achieve the desired mechanical output.
- General arrangement for variable speed drive.

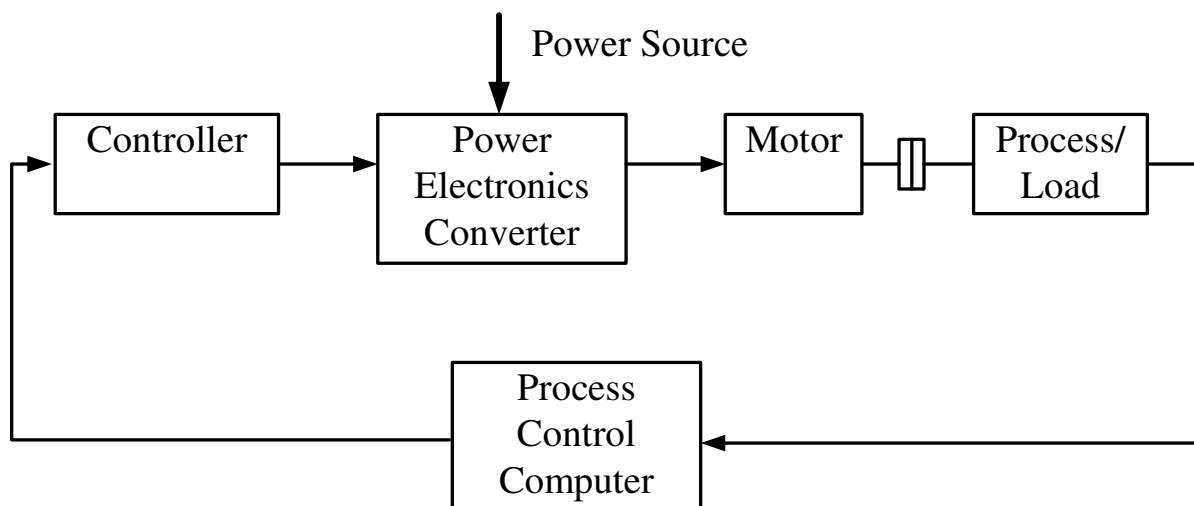

Example of Motor Drive System: Air Conditioning System

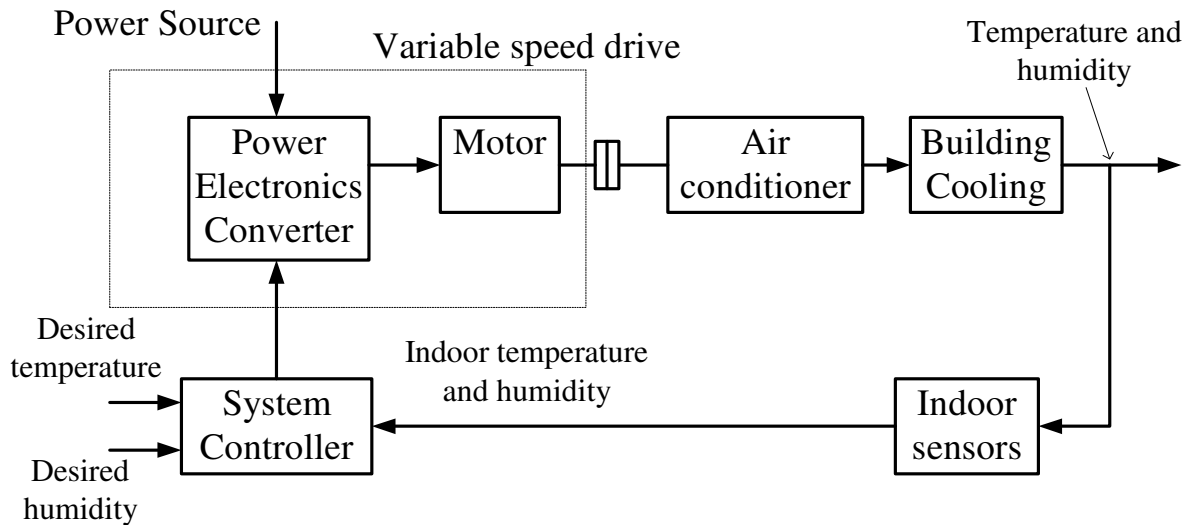

- Three Main Elements of Motor Drives:
 - Electric Motor (DC, AC, SRM, Stepper)
 - Load Type
 - Control
- Requirements of Drives:
 - Variable speed
 - Controllable Torque

Motor: Review of general principles

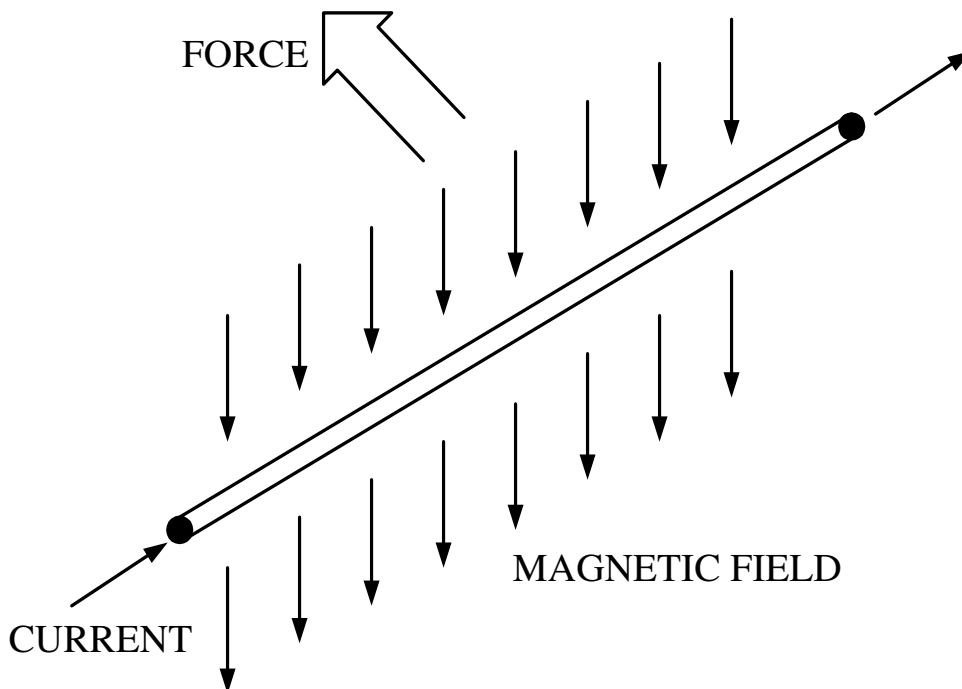

"Left Hand" Rule

- Thumb \Rightarrow Force (F)
- Pointing Finger \Rightarrow Magnetic Field (Flux) (Φ)
- Middle Finger \Rightarrow Current (I)

$$\text{Flux Density : } B = \frac{\phi}{A}$$

$$\text{Force : } F = B \cdot Il$$

A : Area; l : length of current carrying wire

Flux in C-core

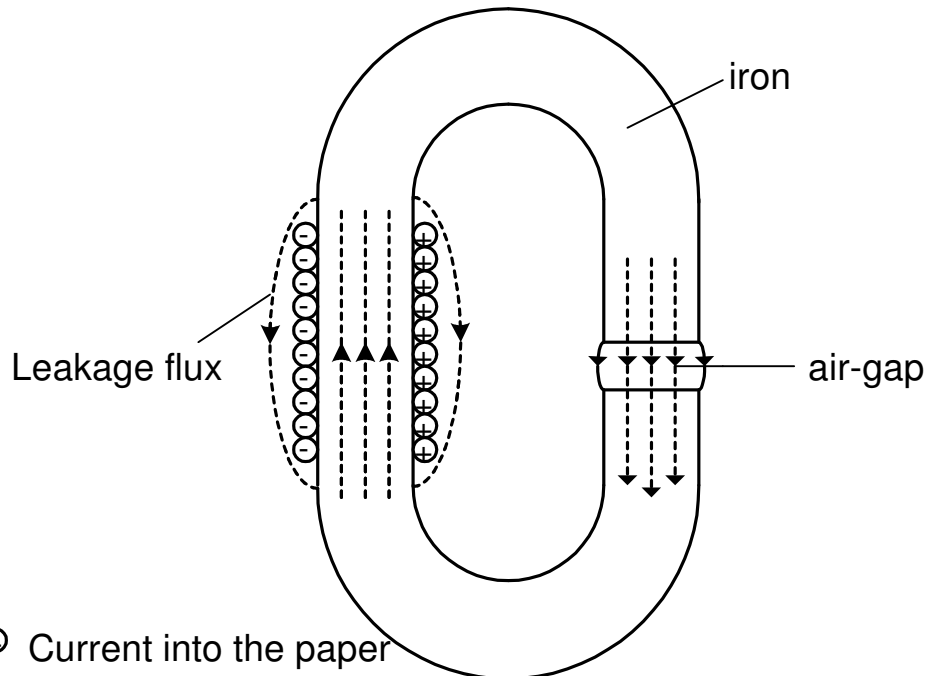

- ⊕ Current into the paper
- ⊖ Current out of the the paper

NOTE: Use right hand "Screw Rule" to determine the direction of flux

Electric - magnetic analogy

$$\text{Current} = \frac{EMF}{\text{Resistance}}$$

$$I = \frac{V}{R}$$

$$\text{Flux} = \frac{MMF}{\text{Reluctance}}$$

$$\phi = \frac{NI}{\Lambda}$$

Air-gap flux densities

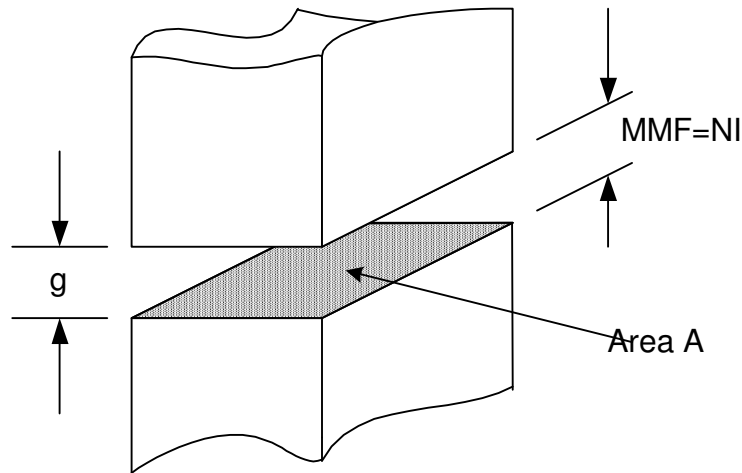

Reluctance of air (in the air - gap),

$$\Lambda = \frac{g}{\mu_0 A}$$

Then,

$$\phi = \frac{MMF}{\Lambda} = \frac{NI\mu_0}{g}$$

$$B = \frac{\phi}{A} = \frac{NI\mu_0}{g}$$

Note that air - gap flux density can be calculated by only knowing the MMF of the coil (NI) and the length of the gap.

The flux density is limited by the saturation of the iron (1.6-1.8T)

Evolution of motor geometry

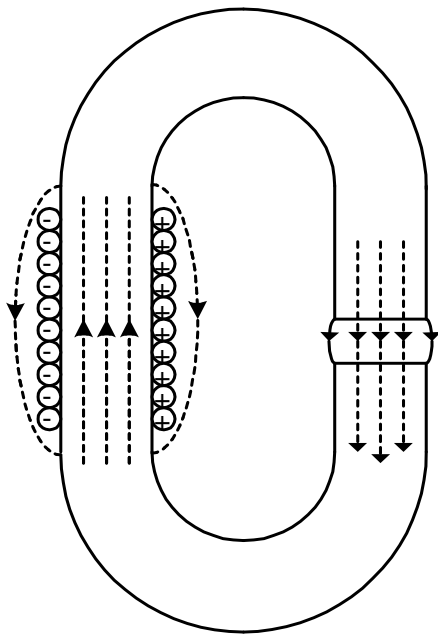

C--Core

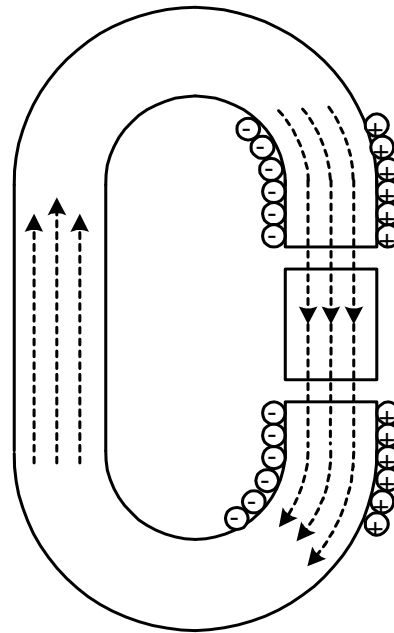

Split air-gap

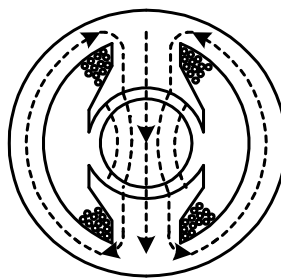

Simple motor geometry

Torque Production

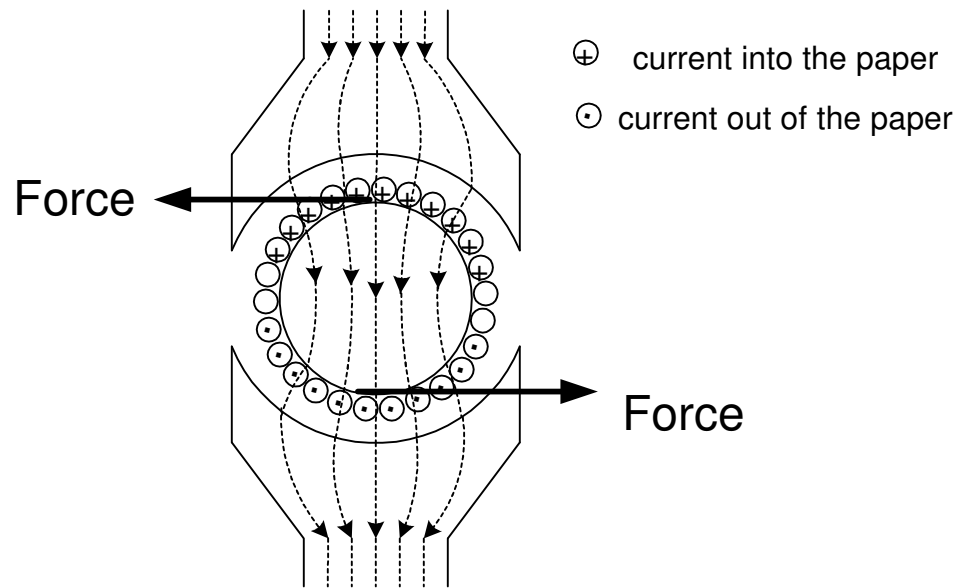

TORQUE PRODUCTION

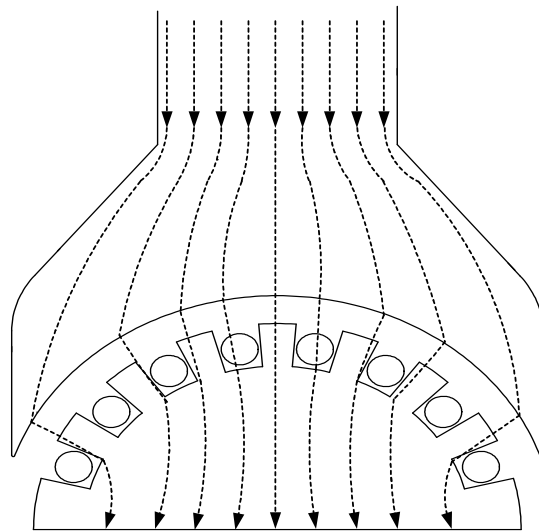

"SLOTING"

Mechanical System requirements for drives: Linear motion

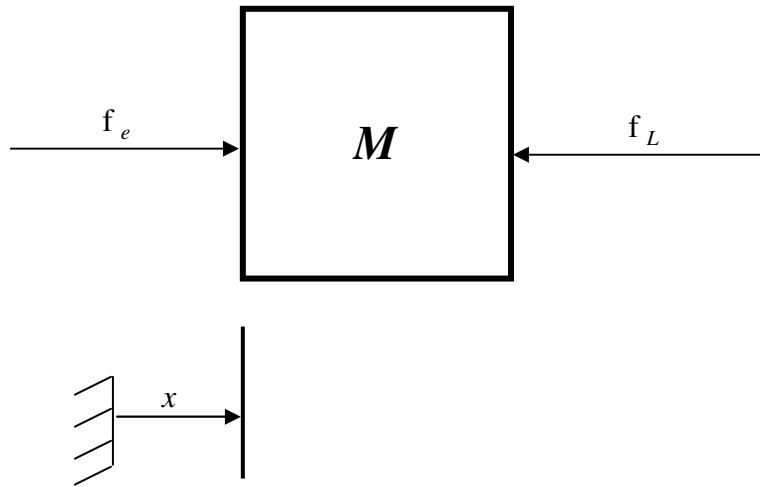

Linear motion :

$$F_M = F_e - F_l = \frac{d}{dt}(Mu) = M \frac{du}{dt} = Ma$$

where

$$a = \frac{du}{dt} = \frac{F_M}{M}$$

Rotating motion

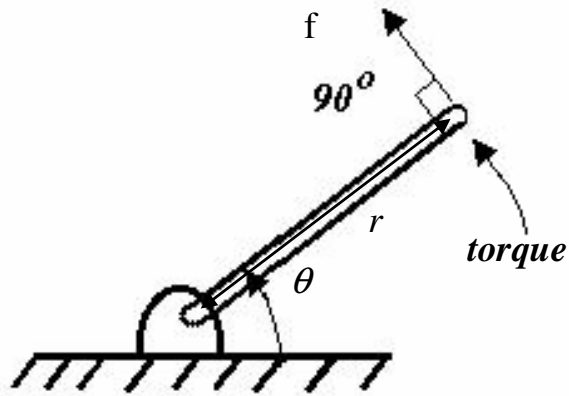

$$T = F \cdot r$$

For moment of inertia, J

$$T = J\alpha$$

α is the angular acceleration, i.e.:

$$\alpha = \frac{d\omega_m}{dt}$$

Then,

$$T = J \frac{d\omega_m}{dt}$$

Motor and load interaction

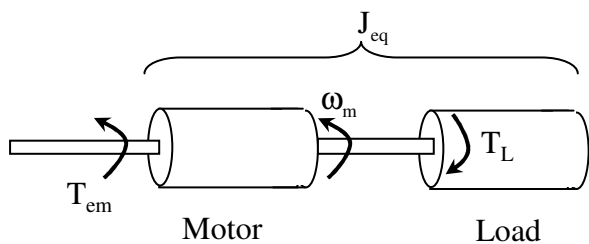

J_{eq} = combined load–motor
moment of inertia

ω_m = motor speed (rad/s)

T_L = load torque

T_{em} = motor torque

T_{em} : Electromagnetic Torque produced by the motor

T_L : Load Torque, plus the bearing friction and wind resistance(drag)

T_J : Net Torque = $T_{em} - T_L$

The difference between T_{em} and T_L causes the combined inertia (J_{eq}) of the motor and the load to accelerate,

$$\frac{d}{dt} \omega_m = \frac{T_J}{J_{eq}}$$

Example(1)

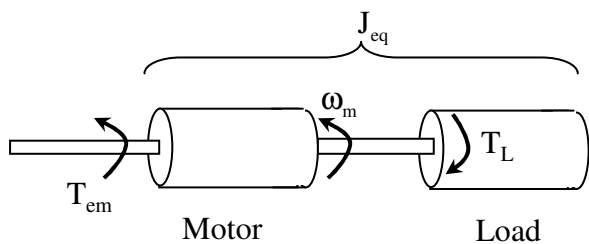

J_{eq} = combined load–motor
moment of inertia

ω_m = motor speed (rad/s)

T_L = load torque

T_{em} = motor torque

Using the motor-load structure as above, assume the motor has a combined inertia of 0.058kgm^2 . The load torque is negligible. Calculate the required electromagnetic torque if the speed is to be increased from standstill to $1,800 \text{rpm}$ in 5sec .

$$\begin{aligned} \frac{d}{dt} \omega_m &= \frac{\Delta \omega_m}{\Delta t} \\ &= \frac{(1800 - 0) \text{rpm}}{5 \text{sec}} \times \frac{1 \text{min}}{60 \text{sec}} \times \frac{2\pi}{\text{rotation}} = 37.7 \text{rad/sec}^2 \\ \Rightarrow T_{em} &= J_{eq} \times \frac{d}{dt} \omega_m = 0.058 \times 37.7 = 1.19 \text{N.m} \end{aligned}$$

Example(2)

The speed profile of the rotating system shown in previous example. ($J_{eq}=0.058\text{kgm}^2$) is shown below. Assume the load torque is 5 N.m. Calculate and plot, as a function of time the electromagnetic torque required from the motor

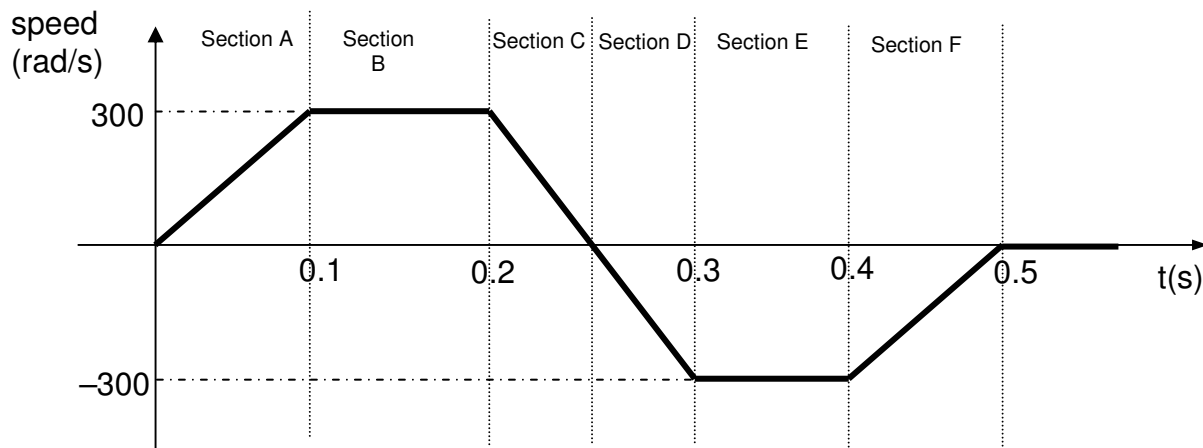

Torque and Power

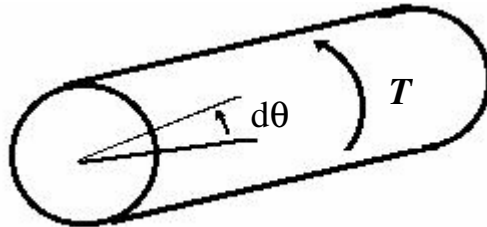

In rotational system, if a net torque T causes the cylinder to rotate by a differential angle θ , the differential work done is :

$$dW = Td\theta$$

If this differential rotation takes place in a differential time dt , then power can be expressed as :

$$p = \frac{dW}{dt} = T \frac{d\theta}{dt} = T\omega_m$$

where $\omega_m = \frac{d\theta}{dt}$ is the angular speed of rotation.

Friction

- Friction within motor and load appose rotation
- Examples:
 - Bearings (to support rotating structure)
 - Air (drag/windage)
 - Diction (friction at zero speed)
- Moving objects:
 - Coulomb friction (independent of speed)
 - Viscous friction (increases linearly with speed)

Load Types

- Centrifugal (squared) Torque
 - Load torque is a function of speed
 - Example: Fans

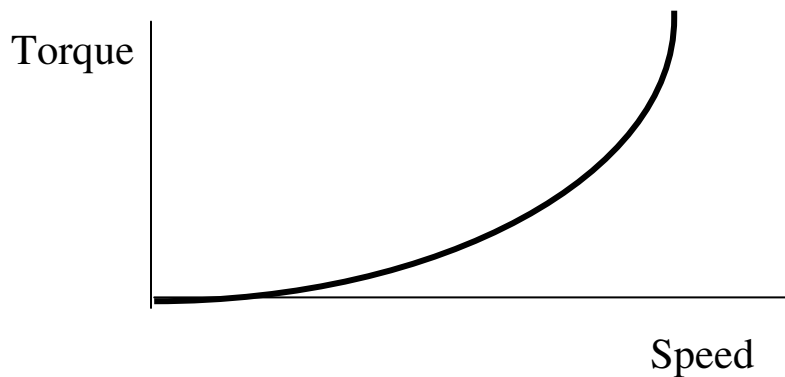

- Constant Torque
 - Load torque is independent of speed
 - Example: Low speed hoist, elevator

